



# **Cranberry**

## **EE396 Final Presentation**



**Jennifer Chun, Joslyn Hamada, Emily Lum**  
**Mentor: Tyrin Besas**

# Overview

- Motivation & Goals
- Block Diagram
- Overall Design
- Power Budget and BOM
- Problems and Solutions
- Final status of project
- Future improvements



# Team Motivation

- Improve hardware of first generation weatherbox
  - Create more efficient power system
  - Reduce size
  - Lower cost
  - Add functionality



# Semester Goals

- Design and populate Cranberry v4.0
- Create a durable housing design
- Populate another Cranberry v3.5

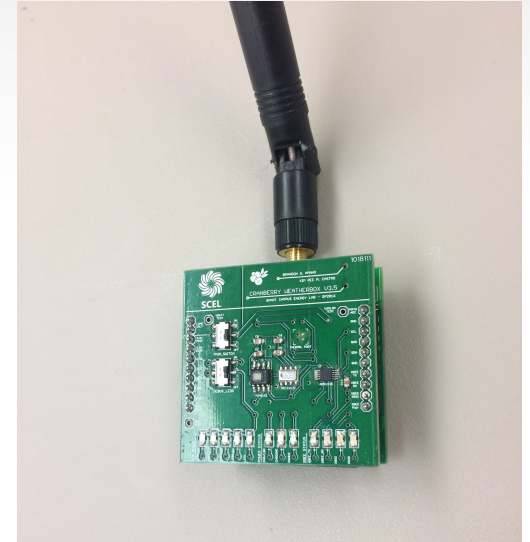

# Block Diagram



# Overall Design

- 2.375" X 2.375" stacked boards
- Top: Sensor Board
- Bottom: Main Board
  - GPS and RTC
- Housing Design
  - Two main parts: box and panels
  - Mounting piece



# Housing Design

- Box
  - Upside down box
  - Board mounted to roof
  - Separate battery compartment
- Panels
- Mounting Piece
  - Borrowed from Apple

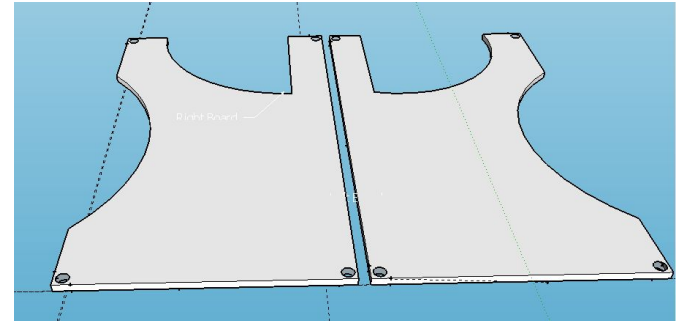
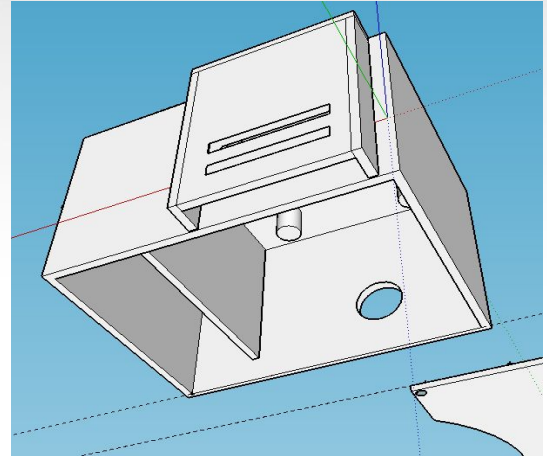

# GPS Comparisons

## Copernicus II DIP (12 Channel)

- Real time clock that works in standby mode
- 3.3 volts
- Header pins
- Requires an external antenna
- Expensive

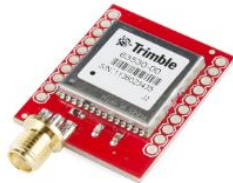

## GPS Receiver - GP-20U7 (56 Channel)

- Standby mode
- Needs an external real time clock
- 3.3 volts
- jst connector
- Cheaper



## Adafruit Ultimate GPS Breakout - 66 channel w/10 Hz updates - Version 3

- Standby Mode
- Needs an external real time clock
- 3.3 volts
- Medium cost

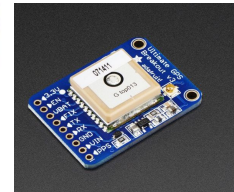



# Real Time Clock

## Adafruit DS3231 Precision RTC Breakout

- I2C
- Breakout board

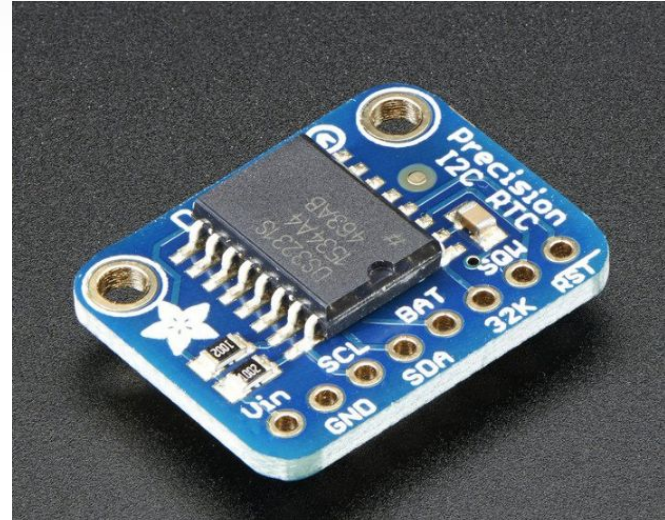

# Power Budget

<b>Cranberry Version 3.5 Power Budget</b>			
<b>3.3 Volt Module</b>	<b>Datasheet Values</b>		
<b>Device Name</b>	<b>Idle (mA)</b>	<b>Typical Current Draw (mA)</b>	<b>Max Current Draw (mA)</b>
XBee Transmit	15.00	205.00	220.00
XBee Receive			
Barometer	0.01	0.01	0.01
Humidity (HIH6031)	0.00	0.65	1.00
V. Reg 3.3V (Main)		0.35	0.90
V. Reg 3.3V (Xbee)		0.35	0.90
Atmega 328P MCU	0.70	1.70	2.70
Irradiance ADC	0.01	0.15	0.30
Irradiance Op Amp		0.80	2.20
Adafruit GPS (MTK3339)		20	
RTC (DS3231)	0.11		0.2
<b>Total Current Draw (mA)</b>	15.83	229.01	228.21
<b>Supply Voltage (V)</b>	3.30	3.30	3.30
<b>Total Power Consumption (mW)</b>	<b>52.23</b>	<b>755.72</b>	<b>753.08</b>



# Bill of Materials

#	Part Name	Unit Cost	Quantity	Sub-Total
1	Solar Irradiance Sensor	\$235.00	1	\$235.00
2	PCB Manufacturing Costs	\$30.00	2	\$60.00
3	6V Solar Panel	\$59.00	1	\$59.00
4	Solar Irradiance Leveling Plate	\$35.00	1	\$35.00
5	3.7V Lithium Ion battery	\$29.00	1	\$29.50
6	XBee Pro S2B	\$29.00	1	\$29.00
7	Humidity Sensor	\$15.13	1	\$15.13
8	Polarized 470 uF Decoupling Capacitors	\$2.26	5	\$11.30
9	External Temperature Sensor	\$9.95	1	\$9.95
10	Solar Irradiance ADC	\$6.51	1	\$6.51
11	Barometer Sensor	\$5.10	1	\$5.10
12	Status and Debugging LEDs	\$0.38	12	\$4.55
13	ATMEGA328P MCU	\$3.70	1	\$3.70
14	XBee Pin Headers	\$1.48	2	\$2.96
15	Polarized 2.2uF Decoupling Capacitors	\$0.69	4	\$2.76
16	Mechanical Sliding Switches	\$1.37	2	\$2.74
17	Miscellaneous Discrete Components			\$17.74
18	Adafruit Ultimate GPS Breakout	\$15.95	1	\$15.95
19	RTC Module	\$14.95	1	\$14.95
<b>Cranberry v4.0 Total Cost</b>				<b>\$545.89</b>



# Problems & Solutions

- Cranberry v3.5 water damage
  - Improve housing
  - Populate a new board
- Parts Delay
- PCB order delay

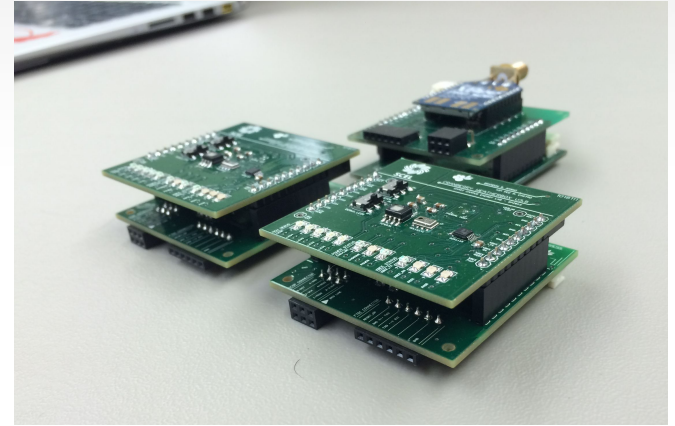

# Progress

- Finished populating another Cranberry v3.5
- Completed Eagle design for Cranberry v4.0
- Finished new housing design
- Tested all the Cranberry boards

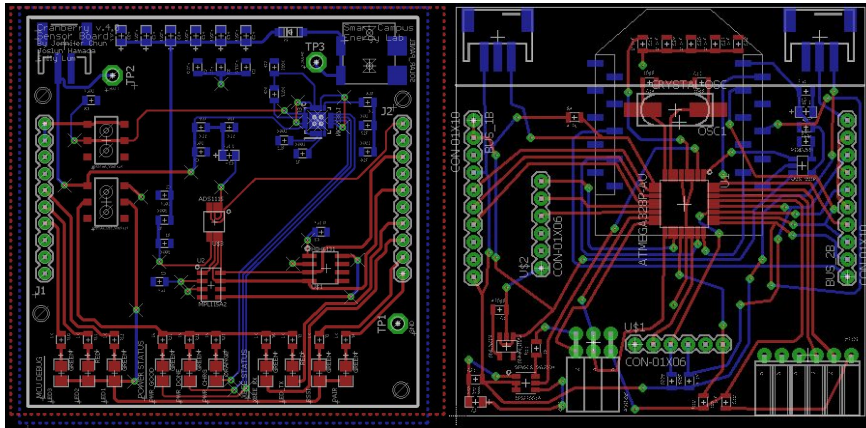

# Progress of Boards

Tested all of the boards to see which ones programmed:

- 3.5 white sensor: doesn't work
- 3.5 white main: doesn't program at all
- 3.5 red sensor: doesn't work (water damaged)
- 3.5 red main: programs, doesn't sync (water damaged)
- 3.5 main: programs, runs, doesn't get data
- Newly soldered 3.5 (BB): programs, syncs, doesn't run



# Future Improvements

- Change GPS and RTC to SMD
- Clean up Eagle design
- Improve housing durability
- Add additional sensors



# Remaining Work

- Redeploy Cranberry v3.5
- Populate and deploy Cranberry v4.0

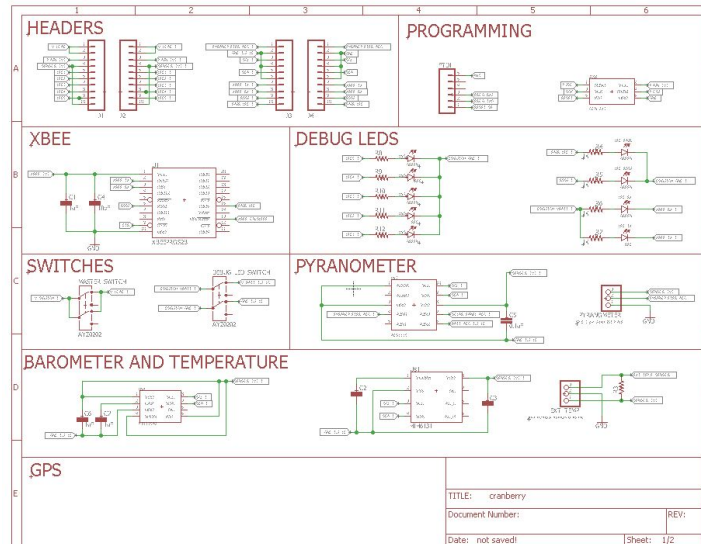



# Any Questions?

