



WIP: Wireless Environmental Sensor Module Generation 3

EE 496 / EE 499 Final Report
Fall 2015 – Spring 2016

*Renewable Energy and Island Sustainability (REIS)
Smart Campus Energy Laboratory (SCEL)*

*Department of Electrical Engineering
University of Hawai'i at Mānoa*

Undergraduate Students: Brandon S. Amano
Kim Pee P. Castro

Advisor: Dr. Anthony Kuh

Date: May 15, 2016
Revision: R3.0

Abstract:

The objective of this final report is to fully document the hardware design of the third generation wireless environmental weather sensor module (Cranberry Weatherbox). This information includes design specifications, design decisions, circuit designs, troubleshooting, bill of materials, power budget, etc. The Cranberry team implemented specific changes, with the goal of improving the overall usability, efficiency, and functionality of the design. Currently, the team has properly debugged the original Cranberry design and has produced two completely redesigned and fully operational weatherboxes. These sensor modules will augment a self-sustaining sensor network, which will collect weather data used for the planning of renewable energy source installations on the University of Hawai'i at Mānoa campus.



TABLE OF CONTENTS

1. Introduction and Motivation	Pg. 4
2. Hardware Design Overview	Pg. 5-11
2.1 Power Subsystem	
2.1.1 Solar Panel and Lithium-Ion Battery	
2.1.2 Battery Charge Management Controller Chip	
2.1.3 3.3V Voltage Regulators and IC Switch	
2.2 Microcontroller (MCU) Subsystem	
2.2.1 ATMEGA328P Microcontroller	
2.2.2 AVRISP MkII / FTDI Programmers and Programming Procedure	
2.3 Sensors and Communications Subsystems	
2.3.1 Barometer Sensor	
2.3.2 Humidity and Temperature Sensor	
2.3.3 External Temperature Sensor	
2.3.4 Pyranometer Sensor	
2.3.5 XBee Pro S2B Transceiver	
3 Hardware Troubleshooting	Pg. 12-15
3.1 Modular Testing Procedure	
3.2 Problems, Solutions, and Testing Results	
3.2.1 Power Subsystem Verification and Testing Results	
3.2.2 Microcontroller (MCU) Subsystem Verification and Testing Results	
4 Cranberry Weatherbox Documentation	Pg. 15-19
4.1 Part Library	
4.2 Schematic Diagram	
4.3 Power Budget	
4.4 Bill of Materials (BOM)	
5 Inter-Team Collaboration	Pg. 20
6 Pending Issues, Improvements, and Future Work	Pg. 20-21
6.1 Fall 2015 Semester	
6.2 Spring 2016 Semester	
7 Conclusion	Pg. 22
8 References	Pg. 23-24
9 Revision History	Pg. 25



1 Introduction and Motivation

Hawai‘i has by far the most expensive electricity prices in the United States due to a heavy dependence on imports of fossil fuels for its energy needs. As seen in Figure 1-1, at \$36.45/kWh, Hawai‘i’s electricity rates are nearly triple the U.S. national average of \$12.32/kWh. In order to reduce this dependency and lower electricity costs, Hawai‘i must look toward more available and sustainable sources of energy. The Smart Campus Energy Lab (SCEL), operating under the Renewable Energy and Island Sustainability (REIS) program, focuses on the research and education of sustainable energy alternatives for the University of Hawai‘i at Mānoa campus. The main project of this lab is the development of a low-cost, wireless environmental sensor module capable of measuring barometric pressure, humidity, temperature, and solar irradiation. These modules will then be integrated into a self-sustaining weather sensor network which will collect data used to optimize planning of future renewable energy source installations and manage risks associated with electricity generation.

Residential Electricity Rates

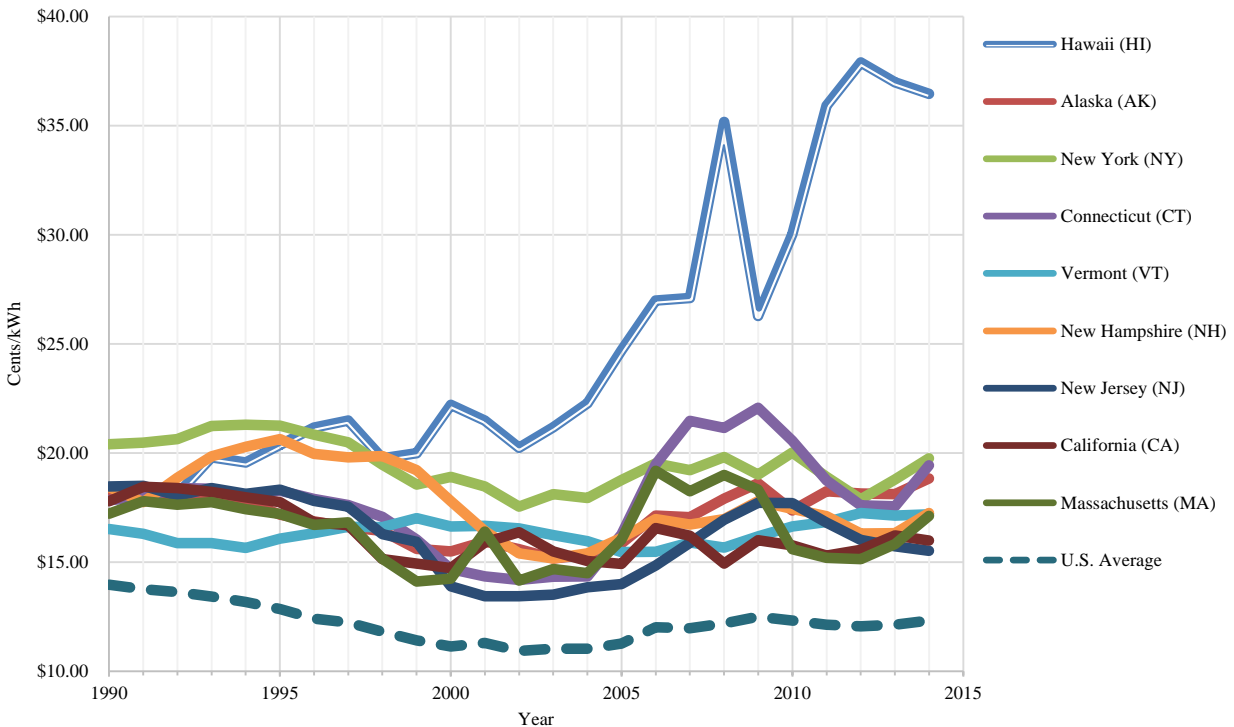

Source: U.S. Energy Information Administration.
Adjusted to 2013 dollars using the inflation factor from U.S. Bureau of Labor Statistics CPI.

Figure 1-1. Residential electricity rates from nine states, plus the U.S. national average.



The main objective of this project was to identify and solve the hardware design problems of the original third generation environmental sensor module, also known as the Cranberry weatherbox (Figure 1-2). Therefore, the main deliverable of the project is to produce a working Cranberry board and an updated, detailed documentation of the current design. A second revision of the board layout was created as well, implementing changes to improve the overall efficiency and functionality of the module. Significant problems of the original design included incomplete documentation, as well as issues with the power and sensor readings. In order to troubleshoot problems with the design, an incremental approach was utilized. The design is divided into four main subsystems: power, microcontroller (MCU), sensors, and communication. In terms of documentation, the schematic was organized and remade using a custom part library to provide proper labeling and improve user readability. Once operational, the modules will be deployed across the University of Hawai'i at Mānoa campus and integrated into the weather sensor network.

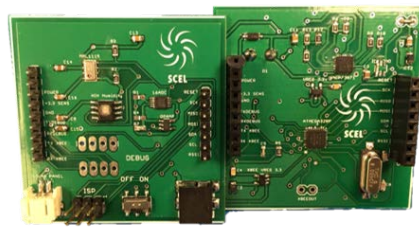

Figure 1-2. The Cranberry weatherbox – Third generation SCEL environmental sensor module.

2 Hardware Design Overview

The main motivation for the design of Cranberry is to improve upon the hardware of the first generation environmental sensor module, also known as the Apple weatherbox. Improvements include a far more efficient power system and an overall reduction in cost and size. Design considerations were also made with the newly established third generation environmental sensor module, Dragon Fruit.

The Cranberry board, consisting of two 2" x 2" printed circuit boards (PCBs) mounted upon each other, represents a footprint reduction of over 85%, when compared to the Apple board's dimensions of 6.299" x 4.288." The main board contains the microcontroller unit (MCU), communications, and power components, while the sensor board contains the barometer, humidity / temperature, and pyranometer sensors. Additional benefits of this modular design is increased accessibility and reparability.

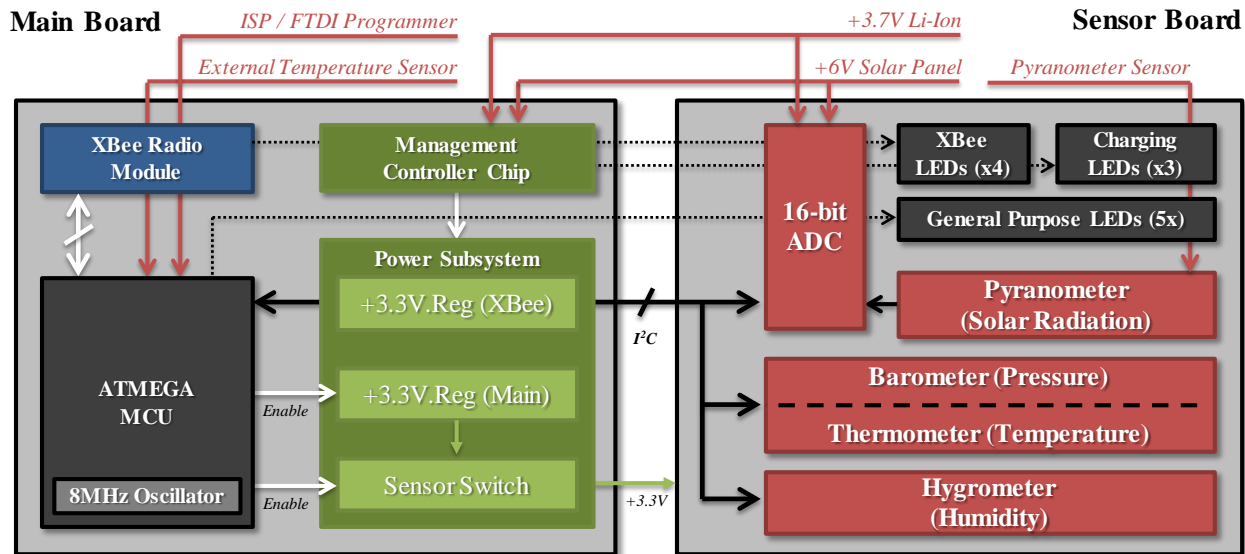

Figure 2-1. Summarized hardware block diagram of the Cranberry weatherbox (v3.5).

A simplified hardware block diagram of the latest version of Cranberry (v3.5) is shown above in Figure 2-1, which shows the two PCB boards and the interactions between the four subsystems. The block diagram also shows the external connections for the rechargeable battery, solar panel, pyranometer, external temperature sensor, and programming pins.

For revision history and organization, the following nomenclature and numbering scheme is utilized throughout the documentation, including but not limited to, this official report, EAGLE schematics, and power budget:

- Cranberry *Version 1.0*
 - Designer: Conrad Chong (Completed: FA2014)
 - Initial, inoperative design of the Cranberry boards being tested and debugged.
 - Contains various design flaws and inconsistencies, as documented in Section 3.2.
- Cranberry *Version 2.0*
 - Designer(s): Brandon Amano and Kim Pee Castro (Completed: FA2015)
 - Produces an operable, albeit with reduced functionality, Cranberry board.
 - Contains the bare minimum fixes and workarounds to the problems with *Version 1*.



- Cranberry *Version 3.2*
 - Designer(s): Brandon Amano and Kim Pee Castro (Completed: SP2016)
 - Significant redesign and overhaul of Cranberry board design.
 - Includes the minor changes from version 2, and in addition, the added functionality and design considerations, that will be discussed in Section 6.
- Cranberry *Version 3.5*
 - Designer(s): Brandon Amano and Kim Pee Castro (Completed: SP2016)
 - Builds upon the design of Version 3.2 and incorporates fixes to several critical design flaws. Design also includes numerous additions and improvements to functionality, as discussed in Section 6.

2.1 Power Subsystem

The power subsystem of the Cranberry board is responsible for supplying power from the battery to all of the electrical components. At the heart of the circuit is a management controller responsible for allowing the solar panel to recharge the battery, whilst supplying power from the battery to the voltage regulators. Many design decisions were made by the original designers of the Cranberry board, in order to decrease its power consumption, such that the boards can sustain extended periods of time without sunlight. These decisions will be discussed further in the following subsections.

2.1.1 Solar Panel and Lithium-Ion Battery

The Voltaic Systems solar panel from Adafruit is a monocrystalline panel measuring 8.7" x 6.9" and is capable of providing up to 5.6W of power at 6V (maximum current of 930 mA). The panel has an efficiency of approximately 17% and is connected to the Cranberry board through a 3.8mm OD/1.3mm ID DC jack ^[1].

Cranberry has been tested primarily with 3.7V, 6,600mAh rechargeable lithium ion battery packs, which has a capacity of 19,536 mWh. Also purchased from Adafruit, these batteries can theoretically supply up to 13A, however it is recommended that the constant current draw be limited to a maximum of



6A. The 2-pin JST cables further limit the current draw since they are rated for only 2A, but fortunately, this is still a non-issue for Cranberry boards. Additional features include *over-voltage*, to prevent over-charging, *under-voltage*, which cuts-out the battery when voltage drops to 3.0V, and *over-current* protection. Since the Li-Ion batteries do not contain thermistors to protect against over-temperature, the recommended charging rate is set at 3A or less ^[2].

2.1.2 Battery Charge Management Controller Chip

By nature, the output voltage and current of a solar panel is entirely dependent on the amount of sunlight. As such, the output of a panel is extremely unstable and fluctuates greatly throughout the day, which is a highly inefficient way to charge a battery. In order to correct this problem, a charging management controller must be used to regulate the charging rate of the battery based off of the output of the panel. Since the solar panel was purchased from Adafruit, the design of the battery charging circuit was based off of their Li-Ion charger breakout board, which was specifically optimized to interface with their solar panels ^[3]. The design utilizes a *Microchip MCP73871 Load Sharing and Li-Ion Battery Charge Management Controller* IC chip.

It is worth noting that research was done by the previous designers on utilizing a true max power point tracker (MPPT) to charge the lithium-ion battery ^[14]. MPPT works by “tracking the voltage and current curves of a solar panel as sunlight changes to maximize the total power.” However, after considering the cost-to-benefit ratio and referencing Adafruit’s design notes ^[3], it was found that using a MPPT would require the use of an expensive DC/DC converter for an efficiency increase of approximately 30%. For a low powered, small panel system, this added efficiency is largely negated by the inefficiency of the DC/DC converter. For this reason, MPPT controllers are generally used for multi-ampere chargers on high powered, large panel systems. Therefore, it was decided to use Microchip’s IC chip to implement a voltage proportional charge control (VPCC) instead.

The voltage divider on the VPCC pin is used to adjust the battery charging current if the output voltage of the solar panel drops to a preset level. Using resistor values of $R1 = 270k\Omega$ and $R2 = 100k\Omega$



sets a threshold value of approximately 4.5V. To further stabilize the output of the solar panel, a large decoupling capacitor is needed. Cranberry v1 and v2 utilize a single, large 4700 μ F polarized capacitor, whereas, Cranberry v3.2 and above utilizes five smaller 470 μ F polarized capacitors placed in parallel. This was done to minimize the space requirement of the weatherbox, with the trade-off of having a higher cost. Finally, a Schottky diode protects the capacitor from discharging back into the panel.

The charging rate of the Microchip controller can be configured by setting the value of the resistor on the *PROG1*, whereas the charge current is calculated using: $I_{REG} = 1000V/R_{PROG1}$. The Cranberry board is designed to charge the battery at its maximum rate of 1A ($PROG1 = 1k\Omega$), but can be configured to charge the battery with a rate ranging from: 50 mA – 1A ($PROG1: 20k\Omega - 1k\Omega$).

Other configurable features and pins of the controller chip are ^[4]:

- CE – CHARGE ENABLE Pin (HIGH)
 - Enable (HIGH) / Disable (LOW) pin of the charging chip.
- SEL – SELECT Pin (HIGH)
 - Configures input power from the solar panel (HIGH), rather than a USB port (LOW).
- TE – TIMER ENABLE Pin (HIGH - Disabled)
 - Internal timer can shut off output to the load, if system draw has been limiting battery charge current for more than a configurable time interval of either 4Hrs, 6Hrs, or 8Hrs.
- PROG2 – USB-PORT CURRENT REGULATION SET Pin (HIGH)
 - Controls current charge rate from USB; irrelevant to Cranberry design.
- PROG3 – CHARGE TERMINATION Pin
 - Resistor value determines when battery charging cycle is completed, which is determined when the average charge current falls below a configurable threshold.
 - $R_{PROG3} = 100k\Omega$ terminates the charge cycle when charge current falls below 10mA.
- THERM – TEMPERATURE QUALIFICATION
 - Since a thermistor is not used to monitor the battery temperature, default resistors values (1k Ω , 10k Ω , and 150k Ω) are used to allow the battery to charge normally.



2.1.3 +3.3V Voltage Regulators and IC Switch

Cranberry board’s components were chosen such that it could be run entirely off of a +3.3V power supply. Furthermore, increased control of the power system from the microcontroller (MCU) provides the SCEL team with a greater flexibility to maximize the overall efficiency of the board through software.

Two Micrel MIC5219 +3.3V LDO regulators supply the +3.3V needed by the Cranberry board’s components. Main specifications and features of the regulators include a maximum 500mA peak output current, very low dropout voltage, ultra-low noise output, and current and thermal limiting [5]. The main regulator, provides power for the majority of the board, including the MCU and sensors. Meanwhile, a secondary regulator is used to exclusively power the XBee transceiver module and can be enabled/disabled by the MCU. The reason for this design is that since the XBee module consumes the most power on the board, operators are given the option to disable the transceiver completely if sunlight is unavailable to recharge the battery for an extended period of time.

Another useful feature is the inclusion of a Texas Instruments TPS27081A IC load switch, that allows the MCU to control power to the sensor board [6]. If power consumption becomes a major concern, the MCU may completely disable all of the sensors to conserve energy.

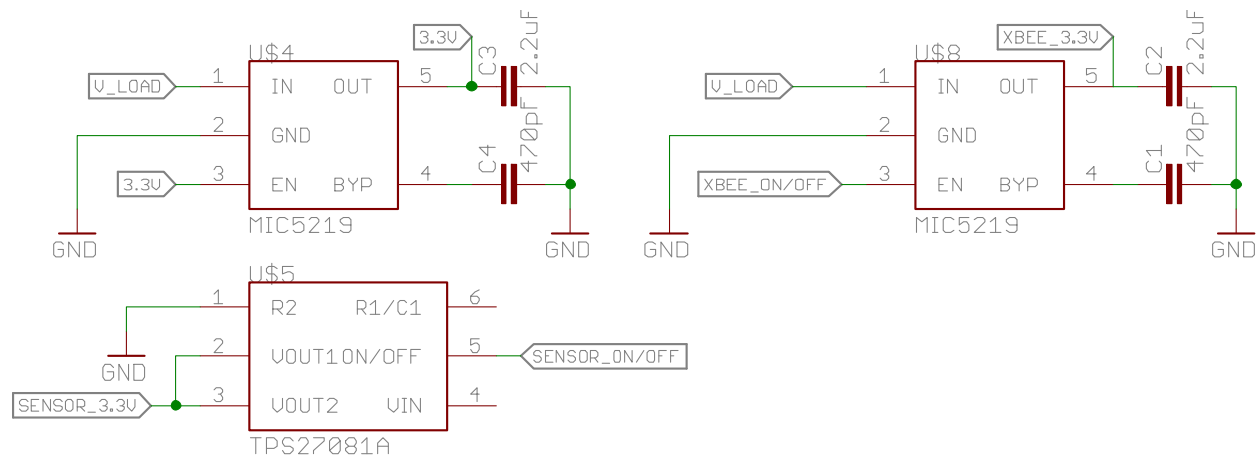
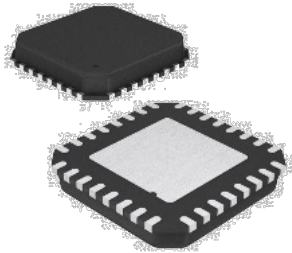

Figure 2-3. +3.3V voltage regulators and IC sensor switch circuit.



2.2 Microcontroller (MCU) Subsystem

2.2.1 ATMEGA328P Microcontroller



The central component of the Cranberry board is the Atmel ATMEGA328P microcontroller. The package chosen is a 5mm x 5mm, 32-pin VQFN with an exposed ground pad, which operates on a supply voltage between 1.8V – 5.5V. According to the datasheet [7], the main features of this microcontroller noteworthy for the Cranberry weatherbox are:

- 8-Bit, RISC Architecture
- Up to 20 MIPS throughput at 20MHz
- 1 Kbyte EEPROM
- 2 Kbytes SRAM
- 32 Kbytes ISP Flash Memory
- Operating Voltage: 1.8V – 5.5V
- 23 General Purpose I/O Lines
- Serial Interface; I²C Compatible
- 8-Channel 10-bit ADC at 15 KSPS
- 5 Software Selectable Power Saving Modes

To further limit the current draw of the ATMEGA, the clock rate was reduced from its default, internal 16MHz to 8MHz through the use of an external quartz crystal oscillator.

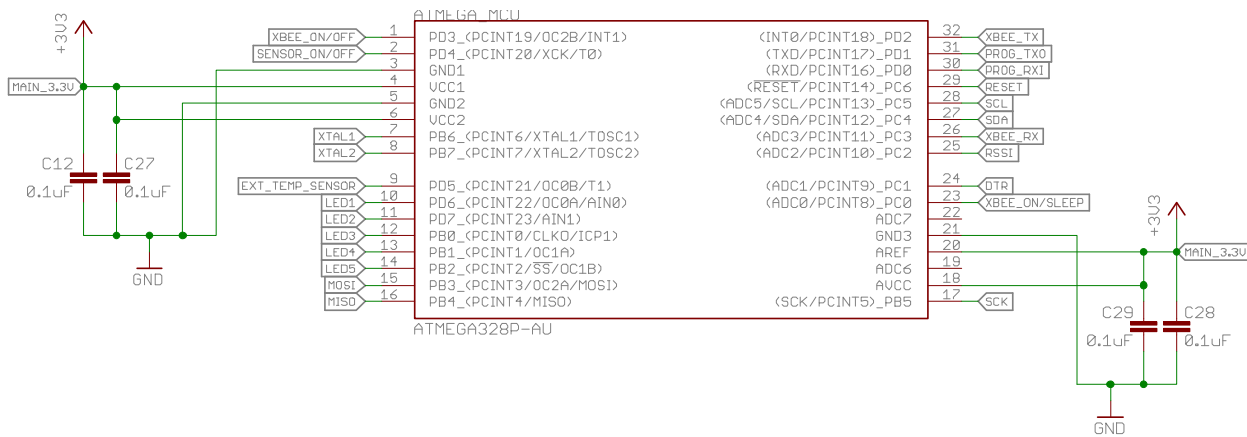

External 8MHz Oscillator

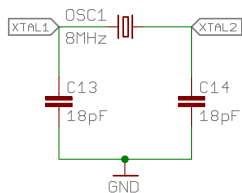

Reset Circuit

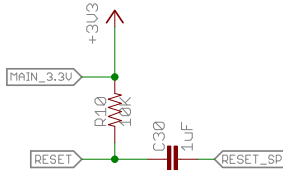

I2C Pull-Up Resistor Network

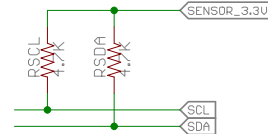

Figure 2-4. ATMEGA328P circuit diagram.



2.2.2 AVRISP MkII Programmer and Programming Procedure

The Arduino IDE is used to program the MCU using an AVRISP MkII Programmer, which connects to the board using an ISP connector, as shown in Figure 2-5. The ISP interface utilizes the following six lines, MISO, SCK, RST, VCC, MOSI, and GND^[8]. Since the AVRISP programmer is unable to provide power to the board during programming, an external voltage source, such as the battery is needed.

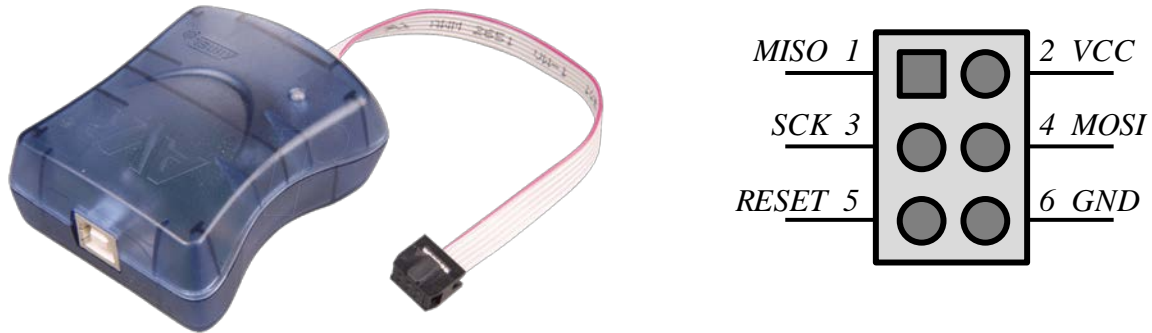

Figure 2-5. AVRISP MkII programmer and the ISP interface.

2.3 Sensors and Communications Subsystems

As an environmental sensor module, a critical subsystem of the Cranberry weatherbox is its sensors array. This array consists of the barometer (pressure), humidity and temperature, and pyranometer (solar irradiance). One of the benefits of the Cranberry board is that all sensors communicate with the ATMEGA MCU through the serial communications protocol, I^2C . This allows all sensor components to share a common serial data line (SDA) and serial clock line (SCL), rather than having each sensor run a separate connection to the MCU. This reduces the amount of traces routed throughout the board and is further simplified by having all the sensors and the MCU running at the same +3.3V voltage level. Having a digital I^2C signal also allows the sensors to directly interface with the MCU, thus reducing the need for signal conditioning and mitigating the risk of signal integrity degradation. Finally, utilizing I^2C allows future Cranberry hardware teams the flexibility to replace or add additional boards with little to no modifications to the main board.



2.3.1 Barometer Sensor

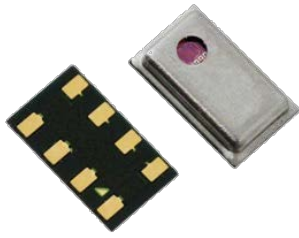

The Freescale Semiconductor MPL115A2 is a barometer, or absolute pressure sensor capable of providing measurements from 50 to 115 *kPa*. The I^2C port sends digitized pressure and temperature sensor readings from an onboard ADC, along with factory calibration data to the ATMEGA MCU.

The MCU can then execute a compensation algorithm to generate a temperature compensated absolute pressure with an accuracy of ± 1 *kPa*.

The sensor is housed in a miniature 5 x 3 x 1.2mm LGA package and when polling, has a low current consumption of only 5 μ A. The sensor contains an active-low SHDN pin to place it into sleep mode and reduce current consumption to only 1 μ A [9].

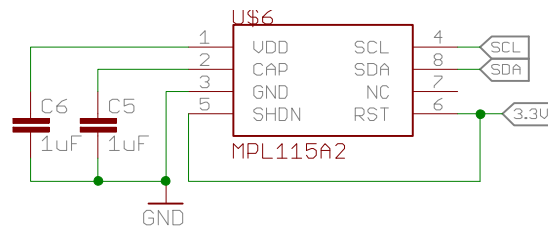
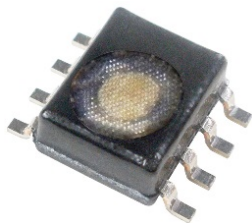

Figure 2-6. Barometer sensor circuit diagram.

2.3.2 Humidity and Temperature Sensor



The Honeywell HumidIcon HIH6131 combines two sensors into the same SOIC-8 pin package, allowing a single chip to measure the relative humidity and temperature. These parameters are measured with a resolution of 14-bits to an accuracy of $\pm 4.0\%$ for humidity and $\pm 0.5^\circ\text{C}$ for temperature. These accuracy levels are applicable for an operating temperature range of $5^\circ\text{C} - 50^\circ\text{C}$ and a relative humidity of 10% – 90%. The chosen package also incorporates a hydrophobic filter with condensation resistance, making it suitable for use in Oahu's various weather environments.

Additional built-in features for power efficiency include placing the sensor into sleep mode when not taking a measurement, allowing the device to consume only 1 μ A, compared to 650 μ A during full operation [10].



Note: The HIH6131 is an updated drop-in replacement for the original HIH6031, which was placed on end-of-life (EOL) support by the manufacturer.

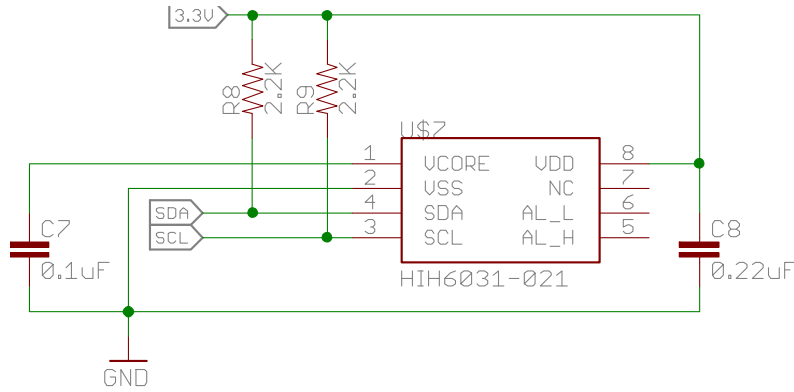
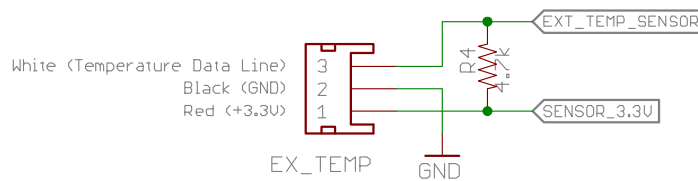

Figure 2-7. Humidity and temperature sensor circuit diagram.

2.3.3 External Temperature Sensor



Starting with version 3.5, the Cranberry weatherbox has the capability to connect to the external sensor used on the Apple weatherbox. The sensor used is a Dallas Semiconductor DS18B20 programmable 1-wire digital thermometer. The temperature resolution can be programmed from 9 to 12 bits and can measure temperatures ranging from -55°C to $+125^{\circ}\text{C}$ ($\pm 0.5^{\circ}\text{C}$) every 750 ms. The sensor communicates directly with the ATMEGA MCU using a 1-Wire interface and has a typical active and sleep current of 1mA and $0.750\mu\text{A}$, respectively. Although a standalone version of the temperature probe can be used, SparkFun’s waterproof package of the sensor with 6 feet of shielded wire is preferred.



SMD 3-pin 2mm JST MALE
JST Connector to SEN-11050 Temp. Sensor

Figure 2-8. External temperature sensor circuit diagram.



2.3.4 Pyranometer Sensor



The main sensor of any wireless environmental sensor module is the pyranometer, which measures solar irradiance, or solar radiation. The SCEL laboratory has two types of Apogee pyranometer sensors that are compatible with specific versions of the Cranberry weatherbox.

- SP-110 - An unamplified model, which is self-powered (i.e. requires no power supply) and provides only a millivolt signal. This sensor requires an operational amplifier circuit before the signal can be processed by an ADC. The sensor is *only* compatible with Cranberry versions 2.0 and earlier.
- SP-212 - An amplified model, which requires a 2.5V – 24V power supply, but provides a 0V – 2.5V cosine output that can be processed directly by an ADC.

Both sensors incorporate a calibrated silicon-cell photodiode that measures solar irradiance and is protected in a housing that keeps the sensor fully weatherproof and self-cleaning. In order to accurately measure the total shortwave radiation, the sensor must be properly mounted using a leveling plate.

The original design of the Cranberry board has a jumper pin to bypass the operational amplifier, thus enabling the use of either sensor. However, due to the untested performance of the operational amplifier circuit, all generations of the wireless environmental sensor modules (Apple, Cranberry, and Dragon Fruit) are now designed to use amplified pyranometers. The potential trade-off of omitting the amplifier circuit is that it requires a connection to the +3.3V power supply, which can draw a nominal current $300\mu A$ ^[11].

The output of the pyranometer is then sent to a Texas Instruments ADS1115 analog-to-digital (ADC) converter. The ADC can perform conversions at a rate of up to 860 samples per second (SPS) at a resolution of 16-bits. As the ADC performs calculations and sends the data to the MCU via I^2C , the device can draw a nominal current of $150\mu A$, before powering down to a current draw of only approximately $0.5\mu A$ ^[12].

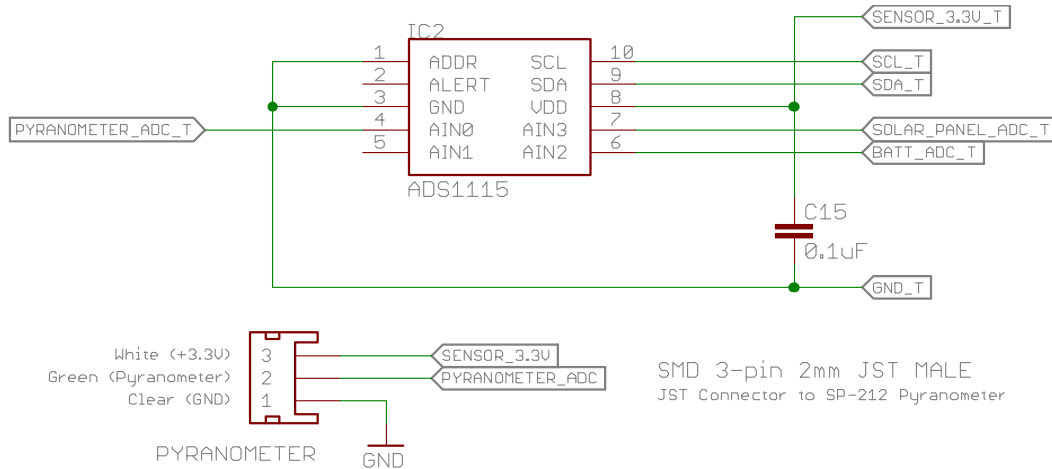
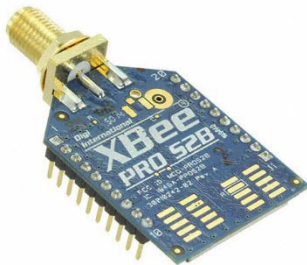

Figure 2-9. Apogee SP-212 pyranometer sensor and Texas Instruments ADC circuit.

2.3.5 XBee Pro S2B Transceiver



The communications module for the Cranberry weatherbox utilizes an XBee Pro S2B RF module which operates using the ZigBee protocol. Operating within the ISM 2.4 GHz frequency band, these modules are optimized to “support the unique needs of low-cost, low-power wireless sensor networks. These modules require minimal power and provide reliable delivery of data between remote devices.” Theoretical specifications for the 63mW transmitter allow transmission distances of approximately 90m for indoor and urban settings and 2mi for an outdoor line-of-sight environment [13].

On a related note, the SCEL networking team is currently testing and verifying the real-world performance of the XBee Pro S2B, specifically, the module’s power consumption and transmission distance. Data from multiple drop-in replacement families of XBee modules are also being measured and compared. Recommendations will then be taken into consideration regarding the particular model most suitable for the final deployment of the Cranberry weatherbox.



3 Hardware Troubleshooting

The majority of work for Cranberry involves troubleshooting hardware related problems of the design. To approach such problems, a general test procedure was first prepared prior to testing. The testing procedure used to identify problems of the design as well as the approach taken when solving each problem will be discussed in greater detail in the following subsections.

3.1 Modular Testing Procedure

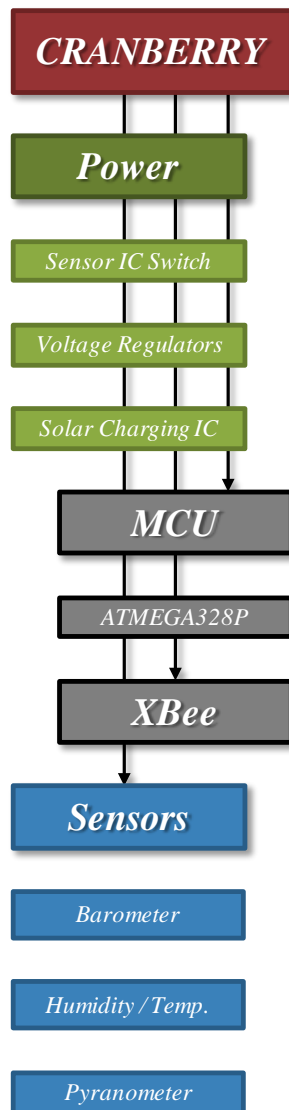

A modular test approach was adopted in order to troubleshoot the problems of the current design. Each subsystem (power, microcontroller unit (MCU), sensors, and communications) was incrementally tested based on a general test procedure. The general test procedure was prepared such that problems were isolated to individual subsystems, allowing for more efficient identification and repair as a result.

The procedure is as follows: first, the schematic of the subsystem was verified based on the component datasheets. Typical application circuits were found on datasheets and compared to the circuit implementations within the current design. The pin configuration of each component was compared to configurations found on the corresponding datasheets to ensure proper implementation. The appropriate components were then soldered on to the board and the module was prepared for testing. Continuity tests were performed to ensure no shorts, opens, or bridged connections occurred following assembly, as well as to verify proper power and ground connections. Finally, if applicable, the validity of I/O values was tested in order to confirm that the components were working as intended.

Figure 3-1. Block diagram depicting the four subsystems of the Cranberry weatherbox.



3.2 Problems, Solutions, and Testing Results

A minor design inconsistency found was the arbitrary mixture of two different package sizes for the SMD resistors and capacitors. Although the original designers preferred the smaller *0603* package to utilize the board space more efficiently, the current Cranberry team determined that the *0805* package size provided to be easier to solder with little to no compromise in the overall footprint size. Admittedly, this is a personal design preference and may be easily changed by future teams.

A more serious problem, more specific to the power subsystem, is the incorrect implementation of the IC load switch. This problem was revealed after reviewing the schematic and comparing the pin configuration and implementation with the corresponding datasheet. It was found that an entirely different part was used to implement the switch. The pinout of the part used in the schematic did not match that of the datasheet. In order to correct the problem, the correct part was recreated using EAGLE and properly implemented in the schematic (shown in Figure 3-2). To account for the error on the physical board, the IC switch is bypassed, which means the sensor board would be constantly powered as a result. This was done as a temporary fix in order to continue with testing and will be accounted for in the next iteration of the design.

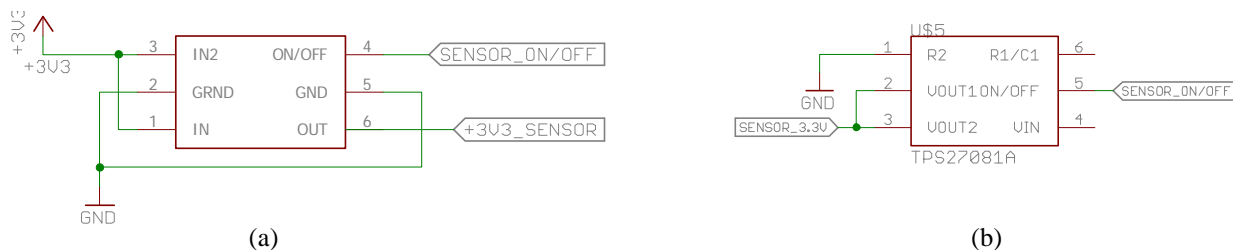

Figure 3-2. Comparison between the *Version 1* IC pin configuration (a) and the datasheet (b).

By reviewing the documentation, it was found that there is an incorrect implementation of the resistor network on the battery temperature monitor (THERM) pin of the charge controller. As mentioned earlier in Section 2.1.2, because a thermistor is not used to monitor the temperature of the battery, the default resistor values, as suggested by the datasheet, are used to allow the battery to charge normally. It



was discovered however, that the chosen resistor values in the design did not match the recommended values stated in the datasheet. As a result, the controller chip would shut off the charging current to the battery prematurely. As shown in Figure 3-3, a simple adjustment to the resistor values solved the problem.



Figure 3-3. Comparison between the *Version 1* THERM resistor values (a) and the datasheet values (b).

3.2.1 Power Subsystem Verification and Testing Results

Once the remainder of the design was verified and all the power subsystem components were soldered, the Cranberry team proceeded with testing the board for proper input and output values. Multiple measurements were taken across different boards, which included the third generation wireless environmental sensor module team's (Dragon Fruit) implementation of the Cranberry board power subsystem circuit. Two Adafruit breakout boards, from which the Cranberry power subsystem circuit was based off of, were also tested and configured with different battery charging rates (500mA and 1A).

The team encountered an additional problem with not getting the expected voltages and currents from the power subsystem. After multiple troubleshooting attempts, including re-verifying the circuit and proper components, it was determined that the charging chip itself was defective and a second Cranberry board was soldered. The final testing procedure for the power subsystem is summarized as follows:

- Simulate the output of the solar panel using a DC voltage source, which is set to output a constant +6V and connected to the solar panel input.
- For each of the following tests, obtain voltage measurements at the source, battery, load, and at both outputs of the +3.3V voltage regulators. For tests with a current draw from the DC power supply (i.e. battery connected with and without the LED load), record the power supply's displayed current draw for I_{source} . *Note:* The team attempted to use a digital multimeter in series with the



power supply to measure supply current, however inaccurate voltage and current readings were obtained from this setup. A theoretized reason is that the internal circuitry of the multimeter affected the charging regulation of the management controller IC chip, therefore, the supply current needed to be recorded using the display of the power supply instead.

- Test Setup
 - Test #1 – Without battery and without load
 - Test #2 – With lithium-ion battery connected and without load
 - Test #3 – With lithium-ion battery connected and with load connected to the main +3.3V voltage regulator output. Load is simulated as a red LED in series with a $1k\Omega$ resistor.

- Test Boards
 - Cranberry #1 – Board containing the defective charging chip.
 - Cranberry #2 – Functional power subsystem
 - Dragon Fruit – Functional power subsystem
 - Adafruit Breakout Board (500mA charging rate; $PROG1 = 2k\Omega$)
 - Adafruit Breakout Board (1A charging rate; $PROG1 = 1k\Omega$)

Table 3-1. Power subsystem voltage and current measurements from multiple boards.

	Parameter	Cranberry #1	Cranberry #2	Dragon Fruit	Adafruit Breakout	Adafruit Breakout
Without Battery Without Load	V_{Source}	6.00V	6.00V	6.01V	6.00V	6.00V
	V_{Batt}	4.06V	4.32V	4.34V	4.30V	4.32V
	V_{Load}	3.98V	5.88V	5.88V	6.01V	5.84V
	$V_{3.3,Main}$	3.569V	3.292V	3.304V		
	$V_{3.3,Xbee}$	3.569V				
With Battery Without Load	V_{Source}	6.00V	5.68V	5.67V	5.69V	4.84V
	I_{Source}	0.01A	0.49A	0.49A	0.50A	1.03A
	V_{Batt}	3.74V	3.82V	3.837V	3.81V	3.88V
	V_{Load}	4.16V	5.37V	5.36V	5.68V	4.53V
	$V_{3.3,Main}$	3.298V	3.294V	3.310V		
	$V_{3.3,Xbee}$	3.290V				
With Battery With LED Load	V_{Source}	6.01V	5.69V	5.66V	(500mA Charging Rate)	(1000mA Charging Rate)
	I_{Source}	0.00A	0.49A	0.49A		
	V_{Batt}	3.74V	3.83V	3.83V		
	V_{Load}	5.84V	5.37V	5.35V		
	$V_{3.3,Main}$	3.299V	3.294V	3.307V		
	$I_{3.3,Main,LED}$	1.51mA	1.50mA	1.51mA		
$V_{3.3,Xbee}$	3.293V					



3.2.2 Microcontroller (MCU) Subsystem Verification and Testing Results

The general test procedure was applied once more to troubleshoot the problems of the MCU subsystem. One problem found through analyzing the schematic was the incorrect use of a coupling capacitor for the RESET signal of the microcontroller. In order to solve this problem, the coupling capacitor was removed from the design. Another problem, related to the assembly of the subsystem, involved difficulty soldering on the MCU. The MCU includes a bottom pad which needs to be soldered to ground. The tools required to solder this component however, were not readily available in the lab. Therefore, in order to assemble the microcontroller, external materials and assistance was required. Solder paste and a hot air rework station were used to solder the ground pad to the board. An alternate package without the bottom pad is being considered for the revision to allow for easier assembly.

Once the MCU subsystem was fully assembled, testing was done to ensure proper implementation of the subsystem. The microcontroller was programmed using the Arduino IDE and AVRISP MkII programmer with assistance from the lab system engineer. A 1 Hz square wave output was observed to verify the output capabilities of the microcontroller, as shown below in Figure 3-4. Further testing with the firmware team is required to ensure the entire microcontroller is working properly. Once the microcontroller is proven operational, it will be programmed to test and verify the sensor and communications subsystems.

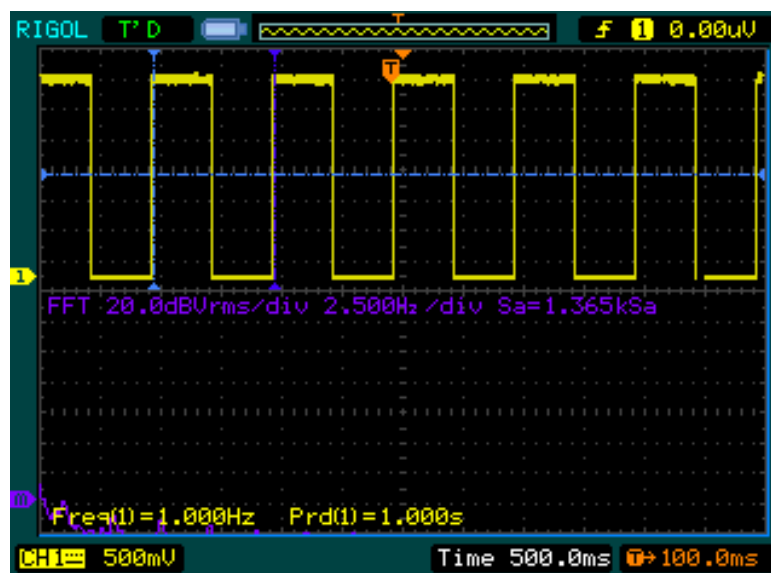

Figure 3-4. 1Hz square wave output of the ATMEGA MCU as seen on an oscilloscope.



4 Documentation

Documentation remains an important part of the troubleshooting and design process. One of the main goals of this project is to update Cranberry's current documentation, including EAGLE part library, schematic, board layout, bill of materials, and power budget for easier accessibility and readability. The use of a custom part library allowed for consistent documentation for each component throughout the schematic. The schematic has been updated to include the hardware repairs made over the course of the semester. An initial power budget and bill of materials was also made and added to the documentation to determine the overall power consumption and cost of the sensor module. A change log of the various problems and related fixes has been maintained in order to observe all changes made to the design. All documentation has been made publically available online through the REIS WIKI.

In order to create the schematic diagram and PCB board layout, CadSoft's EAGLE PCB design software was utilized. It is considered to be one of the leading PCB design programs in the industry. The main features used to update the documentation are the schematic, PCB layout editor, and CAM processor. Furthermore, the software was used for the creation and implementation of custom parts. Along with being available as freeware, an added benefit is the large volume of tutorials and third-party resources available, such as part libraries, design and electrical rule checks, and CAM processors to generate the Gerber files needed for PCB manufacturing. Members of the current Cranberry team also have experience from previous student projects working with EAGLE.

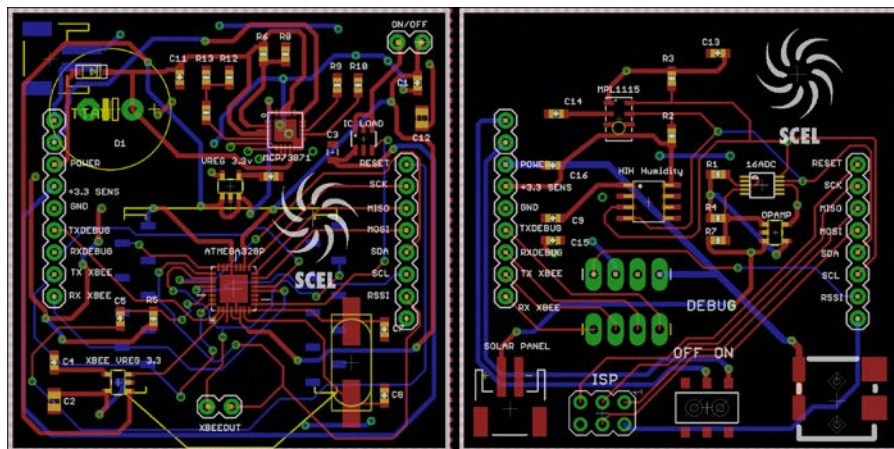

Figure 4-1. EAGLE board layout of Cranberry's main and sensor PCB boards (Version 1).



4.1 Part Library

A custom part library containing individual components relevant to the design was created to compensate for the limited availability of parts in the default and online libraries. This was done for greater independence in terms of part design and consistency of documentation for the schematic as well. Creating custom parts also ensures that the package size and pin configuration of each component matches its corresponding datasheet. Although part creation can be considered an iterative process, a custom part library with a collection of verified devices will contribute to the overall reliability of the fabricated PCB of this design, as well as other related designs in the long term.

A part is composed of three sections: a symbol, a package, and a device. A symbol is the schematic representation of a component. The symbol is used to indicate the pinout of a specific component as well as its connections with other components. Information such as the part name and value are also provided for documentation purposes. As an example, the symbol for the ATMEGA328P microcontroller is shown on the following page, in Figure 4-2(a) below.

The term package is used to indicate the actual part placement on the board layout. More commonly referred to as a footprint or landing pattern, the package is a physical representation of the component. Therefore, it must adhere to the exact design specifications provided by the datasheet, namely pad size and position, as well as package dimension. Conventionally, the component name, value, and a representative outline is visible on the board layout for documentation purposes. In order to verify the measurements of a footprint, the footprint is printed to scale and the corresponding component is placed on top. The part is then examined for proper fit and placement. Adjustments are made accordingly if a component is unable to sit properly on the footprint. The EAGLE package for the ATMEGA328 microcontroller is shown on the following page, in Figure 4-2(b).

The device section links the pin identifiers of the part symbol with the pins of the package. The datasheet is referenced to ensure that the pins are properly connected to the corresponding pads on the package. The prefix for the component reference designator is set to indicate part type as well ^[15].

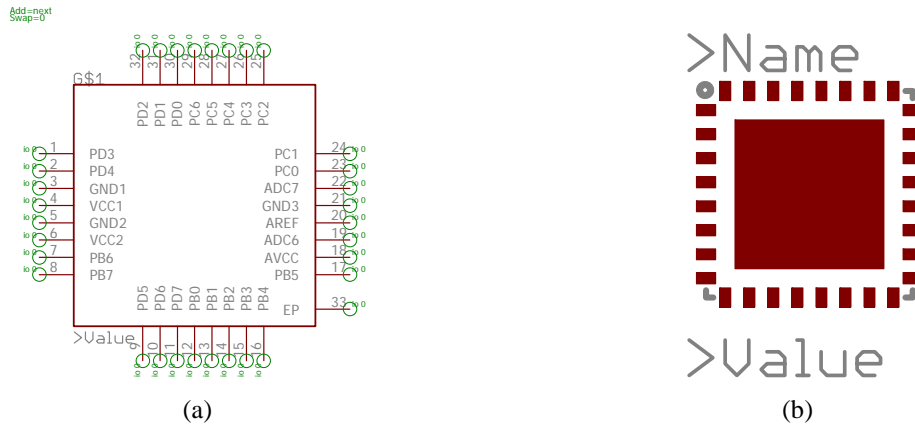

Figure 4-2. EAGLE symbol (a) and package (b) for ATMEGA328P microcontroller.

4.2 Schematic Diagram

One of the main goals of this project is to update and maintain the documentation of the original Cranberry design. In order to identify and solve the problems of the design, the design itself must first be understood by examining previous documentation, specifically research papers and technical documents, such as the schematic diagram and board layout. The available documentation, however, was lacking in detail and somewhat difficult to read through. Therefore, updating the documentation was made a priority in order to gain a better understanding of the overall design, as well as prepare the documentation in such a way that enables future students to inherit the project more easily.

The original schematic had several drawbacks which affected readability. The schematic was comprised of a variety of parts taken from existing part libraries. The libraries used to create the schematic, however, were not documented or stored at any single, easily accessible location. Because components were derived from a wide array of libraries and part designers, there is little to no uniformity between components in terms of documentation as well. The use of part information such as part names, values, and reference designators was inconsistent throughout the schematic. Excessive spacing was used between components, making it much more difficult to trace signals between each component. Overlapping and diagonal connections made it difficult to trace signals as well.

Therefore, the schematic has been reorganized in such a way as to improve user readability and communicate the purpose of the circuit without misunderstanding. The schematic was revised to follow



standard conventions, such as proper labeling and documentation. The design frames were made to fit onto single pages so signals can be traced easily. Components are now grouped based on their corresponding subsystems. Four-way connection points were avoided to be able to distinguish connections more clearly.

The use of a custom part library contributed to the consistency of documentation as well, allowing for greater control over part symbol characteristics. Corresponding part names, values, and reference designators are now included for each component. For general purpose parts with considerable pin counts such as the microcontroller, the symbol was created to match the layout of the component, preserving the physical pin order. Doing so makes it easier to trace signals and understand the pin configuration when reviewing the schematic or debugging. Key nets were renamed to further clarify the purpose of signals. Prefixes were added to signal names in order to clearly differentiate top and bottom signals. Changes to the schematic were made with the goal of improving clarity of the design.

The schematic has been updated dynamically, alongside changes made throughout the entire troubleshooting process. In order to monitor the adjustments made to the design, a revision history was recorded in a change log throughout the semester. The change log contains information regarding each change made to the design. Each entry provides a description of a specific adjustment to the design and justification for why the adjustment was made. An explanation for how the change resolved a problem in the design is provided as well. Along with the details of each change, time and date information is also recorded for documentation purposes. A properly managed change log presents a detailed overview of the progress made during the entire troubleshooting process. The change log can be referenced when reviewing attempted solutions in order to solve existing problems of the design and determine the best course of action.

4.3 Power Budget

A major design improvement for the Cranberry board is its significant increase in power efficiency and battery runtime. On average, the first generation weatherbox, Apple, lasted less than a day without sunlight. One reason for this improvement is the replacement of the Arduino Uno with the ATMEGA328P MCU, which reduces current consumption and eliminates the need for a separate +5.0V voltage regulator.



Other efficiency design changes, as mentioned earlier in Section 2.1, include the addition of MCU controlled power supplies for the XBee and sensor board.

Table 4-1. Average and maximum current and power consumption of major Cranberry components.

Device Name	Ave. Current (mA)	Max. Current (mA)	Ave. Power (mW)	Max. Power (mW)
XBee Transmit	15.02	220.00	49.57	49.57
XBee Receive	0.00		0.00	0.00
Barometer	0.01	0.01	0.02	0.02
Humidity	0.33	1.00	1.07	3.30
+3.3V V. Reg.	0.18	0.90	0.58	2.97
ATEMEGA	1.20	2.70	3.96	8.91
ADC	0.08	0.30	0.26	0.99
Total	16.98	225.81	56.04	68.73

Listed above in Table 4-1 are average and maximum current and power consumption of major Cranberry components, as taken from their respective datasheets. The largest power consumption of 49.57 *mW* comes from the XBee during its data transmissions to the server, despite transmitting for only 0.0109% of the time. After considering all of the major components, the total system consumption is calculated to be, on average 57.36 *mW*, with a maximum of 75.99 *mW*.

The current version of the power budget then makes battery runtime estimates based off of these datasheet specifications. For simplicity, several reasonable assumptions are made when calculating the power consumption and battery runtime:

- Sensors are polling for only half of the time, and otherwise remain in the idle state.
- Voltage regulator leakage current values are assuming a maximum system current load of 50mA.
- Leakage currents of the XBee module are negligible ($mA \gg \mu A$).
- XBee module is acting solely as a transmitter (i.e. does not receive data or acknowledge bits).
- XBee transmit and idle times are assuming binary mode, with a data packet of 82bytes and a transmission rate of 250kbps being sent to the server every 3 seconds ^[16].
- 80% of the battery energy is useable before the battery cuts-out to protect against under-voltage.



Taking into account these assumptions, the projected average battery lifetime of the Cranberry weatherbox is approximately 8 days, 13.67 hours (257.1 hrs). A graph of the battery discharge over time is shown below in Figure 4-3, using both the maximum and average power draws to compare the Apple and Cranberry modules. The graph also includes the battery energy cut-out level, which is based off of the 80% useable energy assumption made earlier. Although real-world testing still needs to be completed for the Cranberry board, the estimated runtime for the Apple board matches reasonably well with its actual observed runtime, thus validating the assumptions made.

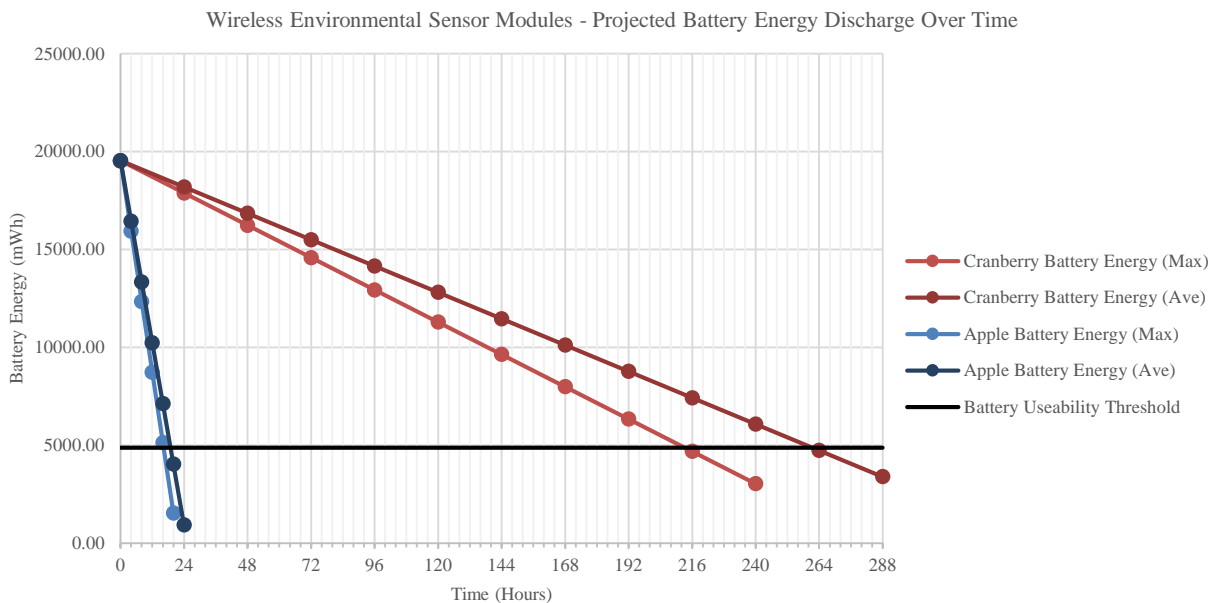

Figure 4-3. Simulated battery discharge, showing the max. vs. average power draws of *Apple* and *Cranberry*.

In the Spring 2016 semester, a discharge test was conducted in order to obtain a more accurate estimate of the Cranberry v3.2’s power consumption. This test involved running the weatherbox module powered solely by the battery in order to determine the measured battery runtime without the solar panel. Conducting this test simulates module performance under cloudy weather conditions when the solar panel is unable to provide power to the module. The sensor module was programmed to operate under standard transmit and receive conditions, with a battery voltage reading taken every 10 minutes. Results of this test are shown in Figure 4-4, which indicates that the sensor module is able to operate and maintain power solely through the battery for approximately four days.

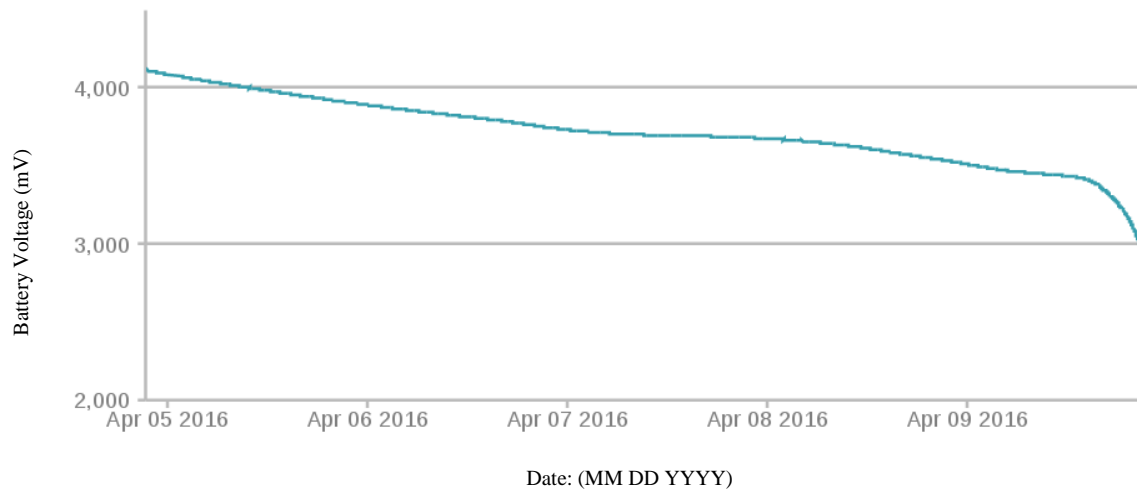

Figure 4-4. Measured battery discharge of *Cranberry* v3.2 under normal operation and transmit conditions.

4.4 Bill of Materials (BOM)

The bill of materials (BOM) is an exhaustive list of components and hardware used in the *Cranberry* design. This includes IC and passive components, connectors, and miscellaneous parts, such as the battery, solar panel, leveling plate, and XBee. Information on quantity, part description, package, mounting type, part value, manufacturer, distributor, and unit cost is included with each material. Reference designators, which relate to specific components on the EAGLE schematic, are included as well. The three costliest components are the Apogee pyranometer sensor (\$235), PCB manufacturing costs (\$60), and the +6V solar panel (\$59). Recent, significant changes to the BOM for Version 3 reflect the replacement of the large 4700 μ F charging chip capacitor with the five smaller, but costlier, capacitors in parallel. The updated BOM also includes all the components required to implement the newest *Cranberry* weatherbox (v3.5), such as the external temperature sensor and debugging and status LEDs. Excluding the cost of the ABS filament and hardware (screws, nuts, etc.) for the 3D printed housing, the total cost of a *Cranberry* weatherbox is calculated to be \$529.94.



Table 4-2. Summarized bill of materials for the Cranberry weatherbox (v3.5).

Device Name	Quantity	Unit Cost (\$)	Sub-Total (\$)
Solar Irradiance Sensor	1	235.00	235.00
PCB Manufacturing Costs	2	30.00	60.00
+6V Solar Panel	1	59.00	59.00
Solar Irradiance Leveling Plate	1	35.00	35.00
+3.7V Lithium Ion Battery	1	29.50	29.50
XBee Pro S2B	1	29.00	29.00
Humidity Sensor	1	15.13	15.13
Polarized 470uF Decoupling Capacitors	5	2.26	11.30
External Temperature Sensor	1	9.95	9.95
Solar Irradiance ADC	1	6.51	6.51
Barometer (Pressure) Sensor	1	5.10	5.10
Status and Debugging LEDs	12	0.38	4.55
ATMEGA328P MCU	1	3.70	3.70
XBee Pin Headers	2	1.48	2.96
Polarized 2.2uF Decoupling Capacitors	4	0.69	2.76
Mechanical Sliding Switches	2	1.37	2.74
Miscellaneous Discrete Components	<i>[Capacitors, Resistors, Headers, etc.]</i>		17.74
Total			\$529.94

5 Inter-Team Collaboration

The SCEL Wireless Environmental Sensor Module project is comprised of numerous individual sub-projects and sub-teams, which include:

- Apple - First Generation Weatherbox
- Cranberry - Third Generation Weatherbox
- Dragon Fruit - Fourth Generation Weatherbox
- Firmware - Platform Agnostic Weatherbox Software
- Verification - Quality Assurance, Process Validation and Documentation Verification
- Networking - Physical and Virtual Network Testing and Simulation
- Server - Data Translator and Aggregator

Another subproject that is set to be integrated with the weatherbox project is the wind sensor team, whose goal is to detect 2D wind speed and direction using an anemometer built with microphones. Anticipating this integration, the schematic for Cranberry was designed to include pins for the connection of the weatherbox to the wind sensor. Due to the potential integration, the future housing design will allow the wind sensor and the weatherbox to be connected by making the anemometer pins accessible.



Inter-team collaboration is extremely beneficial to the debugging process, especially because teams such as networking and firmware are the subject matter experts in their specific area of the SCEL weatherbox project. The networking team provided insight on the necessary requirements needed to operate the applied XBee device. The networking team also identified restrictions on the placement of the XBee device that would potentially result in inefficient and unreliable transmissions from Cranberry. The firmware team provided information on the operations of the weatherbox. These operations include the operation time of the XBee device, or in other words, the time frame and frequency for which it transmits data, and the operation time of the sensors. This includes the time frame and frequency for which the sensors sample data from the environment. With this knowledge, the power budget was corrected for precision on Cranberry's max power consumption.

Communication with other generations of the wireless environmental module teams, such as Apple and Dragon Fruit, also accelerated the debugging process, since various aspects of the design and circuitry overlapped. Often times, these teams encountered similar problems and requirements for their documentation, during which collaboration allowed for a more efficient learning experience for all of the teams involved.

An additional benefit to inter-team communication is the ability to understand how the firmware and verification teams intend to interface with the Cranberry board during programming, testing, and debugging. Ideally, the firmware team will verify that the software will work on Cranberry and the verification team will perform health checks to confirm that each hardware component is operational. In essence, the end goal is to have these teams give a final approval that the board under inspection is ready for deployment into the network.

6 Pending Issues, Improvements, and Future Work

6.1 Fall 2015 Semester

This project is currently a work in progress, and therefore, more work must be done in order to complete the overall goals. In addition to troubleshooting the problems of the sensor and communications



subsystems, a more accurate power budget, a standardized housing design, and a revision of the PCB layout is planned to be completed.

A more detailed power budget will be done to obtain a measured battery runtime of the system. Currently, the power budget is purely theoretical, with the estimated battery runtime calculated based on reasonable assumptions and specifications provided by the component datasheets. Once the system is operational, testing will be done to verify the estimated runtime as well as obtain a more accurate representation of the power efficiency of the module.

A standardized housing for all wireless environmental sensor module generations will be designed once the system is operational. Universal housing will standardize verification and setup of the modules on a large scale regardless of generation. The goal of the housing is to weatherproof the sensor module, allowing it to withstand the expected weather conditions around the University of Hawai'i at Mānoa area. The design must be water resistant in order to protect the system from the occasional rain. Additionally, the housing must allow for easier accessibility to the debug and user interfaces. External connections will be made for access to the debug lines and programming interfaces without the need to disassemble the entire module. Mounting holes will be added to the next iteration of the design to securely install the system within the housing as well. Further research must be done in order to determine an efficient, compact design which can be mass produced at a large scale.

In addition to troubleshooting the problems of the original Cranberry design, one of the objectives of this project is a revision of the current design, implementing specific changes that will improve the overall efficiency of the sensor module. General improvements that can be made to the current design include a more efficient board layout, additional functionality in order to facilitate testing and debugging, and the use of alternative parts and packages to improve the overall quality of the design.

An improvement that will be implemented in the next iteration of the design is a more efficient board layout. The current design has several shortcomings in regards to documentation and routing of the PCB layout. One of the more significant drawbacks of this design is an excessive use of vias. Although vias are capable of reducing signal paths to a certain extent, having fewer vias makes it easier to trace signals



and results in a cleaner design overall. Furthermore, greater consideration can be taken when routing traces. Traces can be organized more cleanly by grouping signals which perform the same function, instead of routing each trace without consideration of design as a whole. The current design lacks on-board documentation, such as component reference numbers and values as well. Although the design may be operational in its current state, organizing the board layout will allow for easier debugging and more effective use of board space for future improvements.

Another change which will improve upon the current design is the use of additional functionality. The current sensor module does not take full advantage of the features and utilities inherently provided by components of the design. One feature which can assist with debugging is the available status pins for the charge controller. These status pins include charging and power status. The status pins can be used with an LED or interface with the microcontroller to indicate when the system is supplied power and when the battery is being charged. Additionally, the low battery output status pin can be used to signal when the battery voltage is low. Thermistors can also be connected to the battery temperature monitor pin of the charge controller in order to prevent the component from operating at high temperatures. Unused ports on the microcontroller can be used to assist in programming and software debugging for the firmware and verification teams as well. Additional sensors, such as GPS, will be researched more thoroughly and carefully considered based on the benefits provided. Furthermore, an I²C port can be implemented to prepare for the addition of new sensors.

Finally, an alternative parts and packages be researched in order to improve overall design quality. The large decoupling capacitor used for the solar panel can be replaced with multiple capacitors of equivalent value to reduce the occupied surface area of the module. Using multiple, much smaller capacitors is much easier to efficiently lay out on a board as well. Further research and testing must be done to verify that such a change will not have any adverse effects on the circuit. For the MCU in particular, a more easily solderable package will be considered. The original QFN package for the ATMEGA was chosen as a way to reduce the chip space. However, the exposed ground pad greatly increased the difficulty of soldering the MCU. Due to the required high level of soldering skill, it was strongly recommended to choose the TQFP



package instead. Although this would increase the size of the MCU footprint by 96% (QFN: 25 mm^2 vs. TQFP: 49 mm^2), the increase in solderability is extremely beneficial for overall assembly and repair. Proper MCU controlled or mechanical power switches will be implemented to replace the jumpers used throughout the current design as well.

6.2 Spring 2016 Semester

Although most of the main goals and deliverables defined at the start of the Spring 2016 semester have been accomplished, some unresolved tasks and recommended improvements remain. Along with populating and deploying the latest version of the Cranberry weatherbox (v3.5), a finalized housing design has yet to be completed. Future improvements to the design include integration of additional sensors, most notably the wind sensor, as well as consideration of alternative part packages and additional functionality to improve the weatherbox's overall accuracy, reliability, and functionality.

A decision was made to create a unique housing design for each weatherbox generation as opposed to creating a standardized design. Although assembly for each weatherbox will differ slightly based on the generation, unique housing designs will provide a sense of identity for each weatherbox generation. By allowing for separate housing designs, each team will have an opportunity to apply their own design preferences and specifications as well as gain experience in 3D CAD design and 3D printing. However, the overall goal of the housing will remain the same: to protect the sensor module from expected weather conditions in the area, while allowing for easy assembly, accessibility, and debugging.

An improvement that has been considered for the next iteration of the design is an alternative part package for the charge management controller chip. The current package for the charge management controller is difficult to solder. Although the package has a small PCB footprint size and thin profile, the QFN package has no leads and includes an exposed thermal/ground pad, making it difficult to solder. As a result, replacing this package will be beneficial for the overall ease of assembly and repair. Unfortunately, the manufacturer does not offer this specific part in other package types. Further research into alternative



charge management controller models as well as substitute manufacturers will be done in order to determine a suitable replacement.

Finally, another improvement to the current design is the integration of additional sensors and functionality. Although the current version has been implemented with status LEDs for software debugging for the firmware team, further improvements can be made to accommodate quality tests done by the verification team. The addition of more sensors will also expand applications of the weatherbox module. The most notable sensor which can be incorporated into the design is the wind sensor currently being developed by SCEL.

7 Conclusion

At the start of the FA2015, the incoming Cranberry team was given a straightforward, and well-defined task, to identify and solve the hardware design problems of the third generation environmental sensor module. Taking over the design of a previous EE 496 senior project involves a relatively large initial learning curve, where detailed documentation is needed to fully understand the hardware and the design considerations made. Therefore, a great amount of time was spent reading the available documentation, such as the research papers, final reports, and datasheets from the previous teams. Major obstacles and challenges were made more apparent as the team encountered many problems due to a lack of comprehensive and sometimes inaccurate documentation. However, because of this, the importance and benefit of proper and thorough documentation was greatly stressed. Team members noted the difficulties encountered and resolved to make sure detailed documentation was written with an intended audience of future x96 students inheriting the project. Another goal for the current documentation is to build upon the previous documentation in order to ensure the original design process and considerations are preserved. For example, this report contains multiple references to the final report made by the original designers of the Cranberry board.

In summary, the third generation wireless environmental sensor module currently three operational board designs: v2.0, v.3.2, and v.3.5. All three versions have had their designs verified and have undergone



full integration with the Firmware team. Further testing is required on top of rooftops to verify the sensor readings and real-world performance of the Cranberry design. Throughout the entire design and troubleshooting process, documentation has been updated and maintained, namely the schematic and board layout of the current design, a custom part library of all components used, an initial power budget and bill of materials to determine the estimated module runtime and cost, and a change log containing revision history.

The design of the weatherbox has been consistently divided into four main subsystems: power, MCU, sensors, and communications. Whereas, a modular approach was taken to identify and solve the hardware problems of the original design, localizing problems to individual subsystems. Future work involves updating the power budget based on measured values, designing the individualized housing for all sensor module generations, and researching future improvements for the components and hardware design. Overall, the Cranberry Team will be delivering to SCEL a revised and well documented, fully operational Cranberry weatherbox ready for deployment across the University of Hawai'i at Mānoa campus.



Datasheet References

1. “Huge 6V 5.6W Solar Panel,” Adafruit, 2015, <<https://www.adafruit.com/product/1525>>
2. “Lithium Ion Battery Pack - 3.7V 6600mAh,” Adafruit, <<https://www.adafruit.com/product/353>>
3. “USB, DC, and Solar Lipoly Charger Overview,” Adafruit, July 2012, revised May 2015, <<https://learn.adafruit.com/downloads/pdf/usb-dc-and-solar-lipoly-charger.pdf>>
4. “MCP73871 Management Controller” Datasheet, Microchip Technology, July 2008, revised Sept. 2013, <<http://ww1.microchip.com/downloads/en/DeviceDoc/20002090C.pdf>>
5. “MIC5219 LDO Regulator,” Micrel, June 2009, <<http://www.micrel.com/PDF/mic5219.pdf>>
6. “TPS27081A High Side Load Switch” Datasheet, Texas Instruments, Apr. 2012, revised Jun. 2015, <<http://www.ti.com/lit/gpn/tps27081a>>
7. “Atmel ATMEGA328/P” Datasheet, Atmel Corporation, revised Nov. 2015, <http://www.atmel.com/images/Atmel-8271-8-bit-AVR-Microcontroller-ATmega48A-48PA-88A-88PA-168A-168PA-328-328P_datasheet_Complete.pdf>
8. “AVRISP MkII” User Guide, Atmel Corporation, revised Oct. 2014, <<http://www.atmel.com/webdoc/avrismkii/index.html>>
9. “Miniature I2C Digital Barometer” Datasheet, NXP Semiconductors, revised Feb. 2013, <http://cache.nxp.com/files/sensors/doc/data_sheet/MPL115A2.pdf>
10. “Honeywell HumidIcon Digital Humidity/Temperature Sensors” Datasheet, Honeywell Sensing and Control, revised May 2015, <<http://sensing.honeywell.com/honeywell-sensing-humidicon-hih6100-series-product-sheet-009059-6-en.pdf?name=HIH6131-021-001>>
11. “Pyranometer Models SP-212 and SP-215” Owner’s Manual, Apogee Instruments, revised Oct. 2014, <http://www.apogeeinstruments.com/content/SP-212_215manual.pdf>
12. “ADS1115 Analog-to-Digital Converter” Datasheet, Texas Instruments, May 2009, revised Oct. 2009, <<http://www.ti.com/lit/gpn/ads1115>>
13. “XBee / XBee-PRO ZigBee RF Modules” User Guide, Digi International Inc., Apr. 2008, revised Mar. 2015, <http://ftp1.digi.com/support/documentation/90000976_W.pdf>



SCEL and REIS References

14. Chong, Conrad. “Weather Sensor Node Hardware.” University of Hawai‘i at Mānoa. Dec. 2014, revised June 2015.
15. Liang, Jonathan. “Introduction to CadSoft EAGLE.” University of Hawai‘i at Mānoa. revised Oct. 2015.
16. Pham, Andy H. N. “Weather Sensor Network.” Thesis. University of Hawai‘i at Mānoa, Aug 2015.

Picture References

1. Atmel ATMEGA328P
<http://media.digikey.com/Renders/Atmel%20Renders/313;32M1-A;M;32.jpg>
2. AVRISP MkII Programmer
http://cdn-reichert.de/bilder/web/xxl_ws/A300/AT_AVRISP_03.png
3. Miniature I2C Digital Barometer
<http://media.digikey.com/Photos/Freescale%20Photos/8-TLGA.jpg>
4. Honeywell Humidity / Temperature Sensors
<http://sensing.honeywell.com/soic-8-smd-with-filter-highres-photo.jpg>
5. Temperature Sensor – Waterproof (DS18B20)
<https://cdn.sparkfun.com/assets/parts/6/4/1/2/11050-04.jpg>
6. Apogee Pyranometer
<http://www.apogeeinstruments.com/amplified-0-2-5-volt-pyranometer-sp-212/>
7. XBee Pro S2B Transceiver
<http://media.digikey.com/Photos/Digi%20Int'l%20Photos/XBP24BZ7SIT-004J.jpg>



Cranberry Report Revision History

R3.0 May 15, 2016

- Revision to include EE 499 updates and progress.
- Revision to include Cranberry v3.2 and Cranberry v3.5.
- Updated the block diagram, BOM, circuit diagrams, and references to reflect the latest version of Cranberry (v3.5)
- Added pyranometer and ADC sensor circuit (Figure 2-9).
- Added Sections: 2.3.3, 6.2, 6.2
- Added Appendix I.

R2.0 January 31, 2016

- Double-spaced report
- Spelling corrections to *Power Budget* section
- Corrections to figure labeling and references
- Minor formatting, spelling, and grammar corrections
- Replaced logos and EAGLE schematic screenshots with high resolution, vector images.
- Included *Cranberry Report Revision History* section.
- Included Figure 1-2: Picture of Cranberry boards.
- Included in *Introduction and Motivation* a reason for Hawai'i's costlier electricity rates.

R1.0 December 18, 2015

- Original Document

SOLAR CHARGER

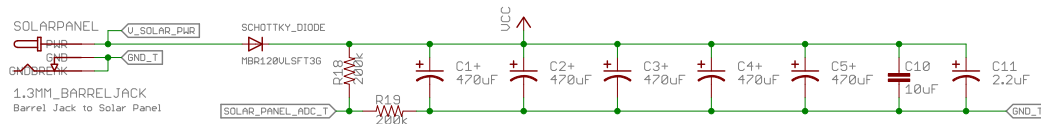

Solar Panel output ranges from 0V - 7.2V (Maximum), 6V Nominal.
 Solar Panel ADC: Voltage divider provides a 0-3.6V analog signal to the ADC for solar panel voltage readings by the MCU.
 Voltage Divider: Req = 100k; Ieq = 18uA (Max), 15uA (Nom); Scaling Factor: 2

Battery output ranges from 3V (Cutout) - 4.2V (Maximum), 3.7V Nominal.
 Battery ADC: Voltage divider provides a 0-3.13V analog signal to the ADC for battery voltage readings by the MCU.
 Voltage Divider: Req = 38.1k; Ieq = 28.5uA (Max), 18.4uA (Nom); Scaling Factor: 1.34

Max input impedance for ADS1115 < 6Mohm vs. ATMEGA < 10kohm
 2.2uF capacitors used to buffer ADC current draw during readings due to high impedance (Req) of resistors.
 1% tolerance resistors are used for the voltage divider circuits for increased accuracy when reading from the ADC. (R18-R21)



Charge Rate = 1000U/RPROG1
 RPROG1 = 1.0K = 1000mA
 RPROG1 = 2.0K = 500mA

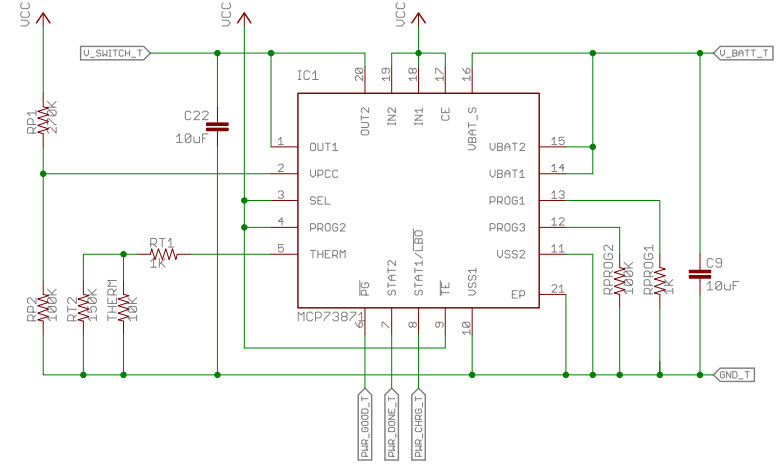

Uswitch - Due to IC smart load sharing, voltage output swing of charging chip ranges from Ubat (3.7V nom) to Uosolar (7.2V max).

MICROCONTROLLER

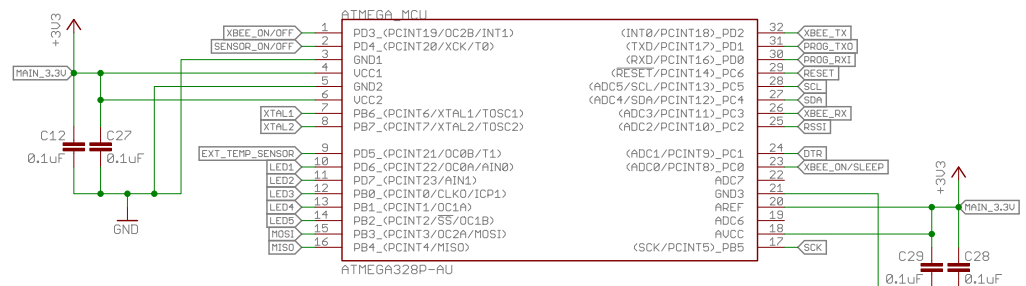

External 8MHz Oscillator

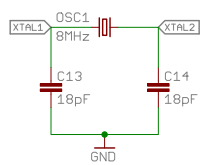

Reset Circuit

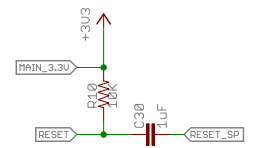

I2C Pull-Up Resistor Network

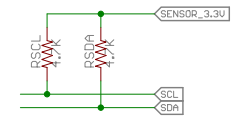

VOLTAGE REGULATION

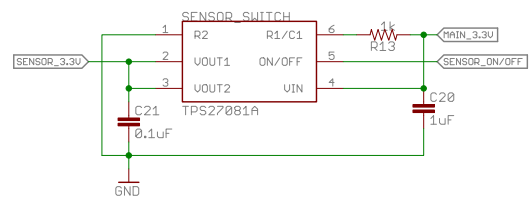
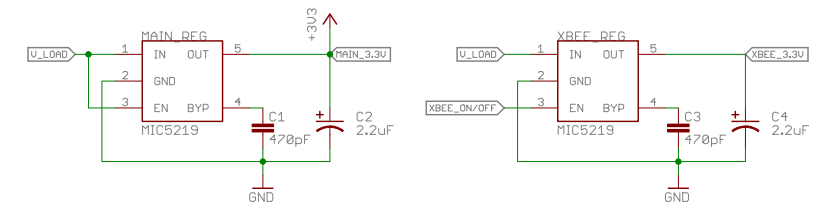

Slew Rate Control - Limits Inrush Currents
 - For Fastest Output Rise Time - R2 to GND, No Cap b/w UOUT and R1/C1
 R1 > 10*R2

XBee / SENSOR ON/OFF - Positive logic MCU enable signals

Title:	cranberry_cc3.5.0
Version:	Cranberry 3.5.0 (BSA)
Date:	4/28/2016 10:05 PM
Drawn By:	Kim Pee Castro, Brandon Amano
	1/1

DEBUGGING ARRAY AND BUS LINE

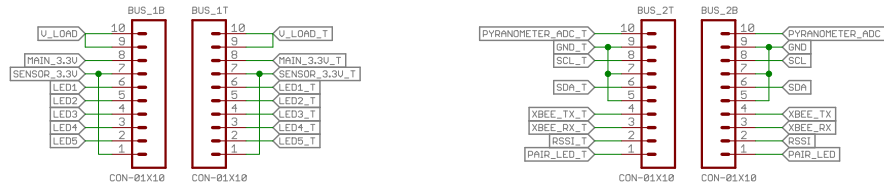

Sensor Board (Top)
Main Board (Bottom)

Nomenclature: All signals on the top board are denoted with the suffix "_T".
Bus Lines provide connections between the stackable main board (bottom) and sensor board (top).

PYRANOMETER (SOLAR IRRADIANCE)

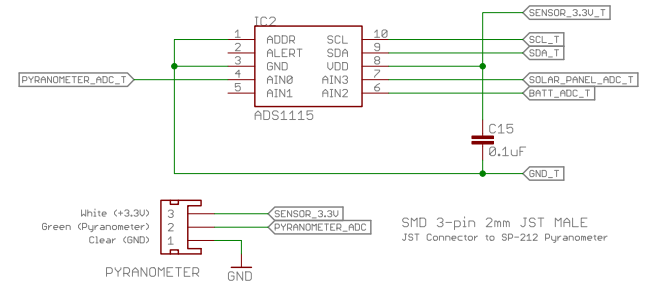

SMD 3-pin 2mm JST MALE
JST Connector to SP-212 Pyranometer

PROGRAMMING

ICSP Connector



FTDI Connector



Notes:
PROG_RXI <-> FTDI_TXO
PROG_TXO <-> FTDI_RXI

Note: Connectors use right angle female headers.

XBEE COMMUNICATIONS

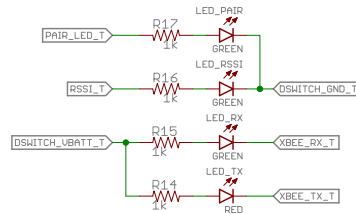
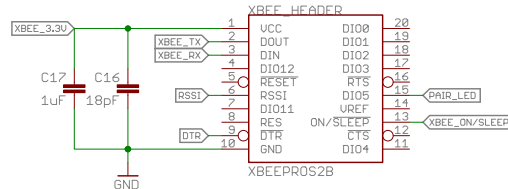

XBee Pro Set S2B and Network Activity LEDs
Note: See XBee Datasheet for "Keepout Area" routing recommendations.

BAROMETER and TEMPERATURE

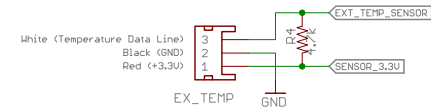

SMD 3-pin 2mm JST MALE
JST Connector to SEN-11050 Temp. Sensor

Waterproof package of DS18B20 sensor purchased from SparkFun (SEN-11050).
Dallas Semiconductor External Digital Temperature Sensor (DS18B20)

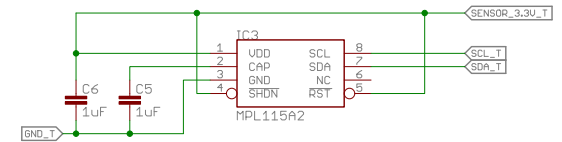

Sensor configured by firmware to double as a barometer and temperature sensor.
Freescale Semiconductor Digital Barometer (Pressure) and Temperature (MPL115A2)

GP DEBUGGING LEDES

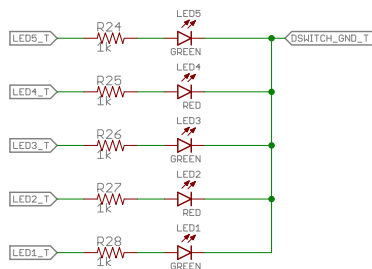

LED1-5 - General purpose, positive logic MCU LEDs

USER INTERFACE



Debug LED Switch:
OFF - Switches off all LEDs for rooftop deployment.
ON - Switch provides PWR and GND connections for the charging, XBee, and GP LEDs.
Note: Operates LEDs independent of Master Switch (draws power directly from battery).

Master Switch: Removes ONLY the load from the charging circuit. (i.e. Solar panel can still charge the battery while OFF).

HUMIDITY

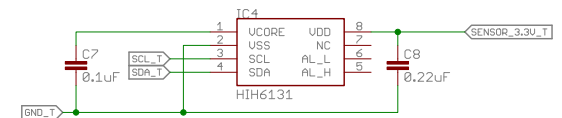

Honeywell Digital Humidity/Temperature (HIH6131)

Title:	cranberry_cc3.5.0
Version:	Cranberry 3.5.0 (BSA)
Date:	4/28/2016 10:05 PM
Drawn By:	Kim Pee Castro, Brandon Amano
	1/1