

Smart Campus Energy Lab

WIP: Environmental Sensor Network Nodes

Students: Emily Lum (496), Joslyn Hamada (No Credit), Jennifer Chun (No Credit), Emily Kane (396)

Project Advisor: Dr. Anthony Kuh

Smart Campus Energy Lab - Renewable Energy and Island Sustainability

Introduction & Motivation

- In 2012, the University of Hawaii at Manoa (UHM) paid \$35 million for their electricity bill. Despite the implementation of energy efficient measures, UHM paid \$34.3 million for their electricity bill in 2014. This is due to the fact that the price of electricity per kilowatt hour has increased greatly.
- SCEL is in the process of creating a wireless environmental sensor network to collect data used to forecast solar irradiation patterns and determine optimal places to install renewable energy sources on the UHM campus.

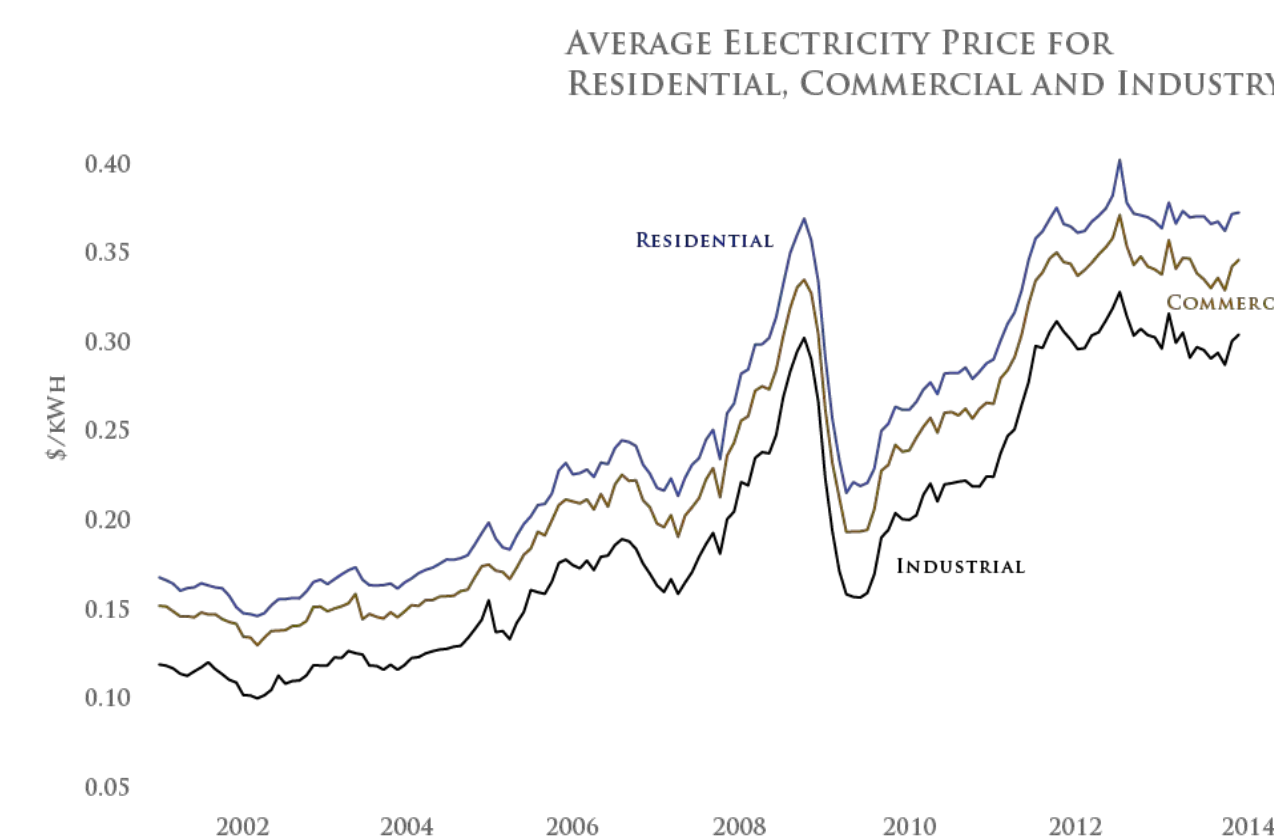

Figure 1: Electricity prices in Hawaii
Source: University of Hawaii Economic Research Organization

Project Description

Objective: Design and build a low cost, low power consumption sensor module that collects data on various weather characteristics, such as solar irradiation, temperature, humidity, and pressure.

- Improve the hardware of the third generation weatherbox modules by increasing functionality, data reliability, and ease of use
- Modify sensor modules to include GPS and Real Time Clock
- Design weatherproof housing for sensor node
- Deploy the sensor modules on rooftops of buildings around the UHM campus
- Collect and store data in real time in a database on a local server and use it to predict solar irradiance patterns around campus

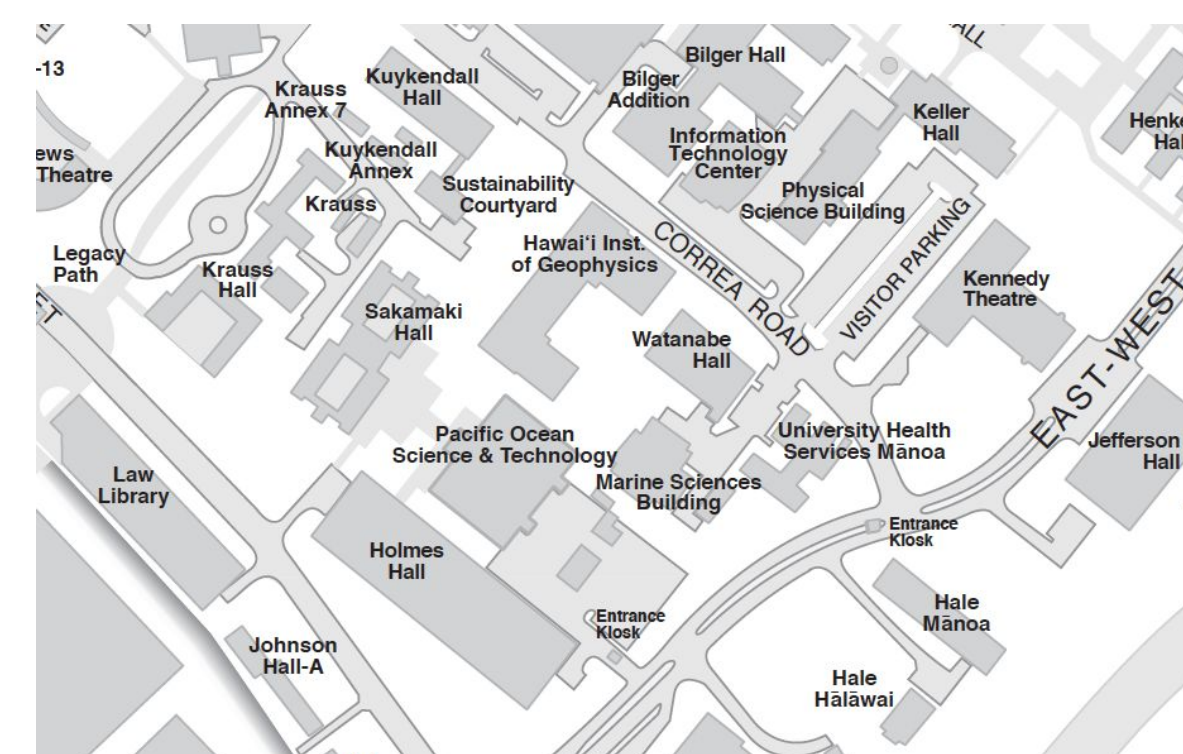

Figure 2: Planned sensor module deployments on the upper UHM campus buildings: Holmes, Sakamaki, MSB, HIG, and Kuykendall

Results

- Deployed one Cranberry v4.0 board in Kaneohe for initial testing
- Populated two Cranberry v4.1 boards and began debugging
- Simulated and measured energy consumption and battery runtime
- Design weatherproof housing for sensor node

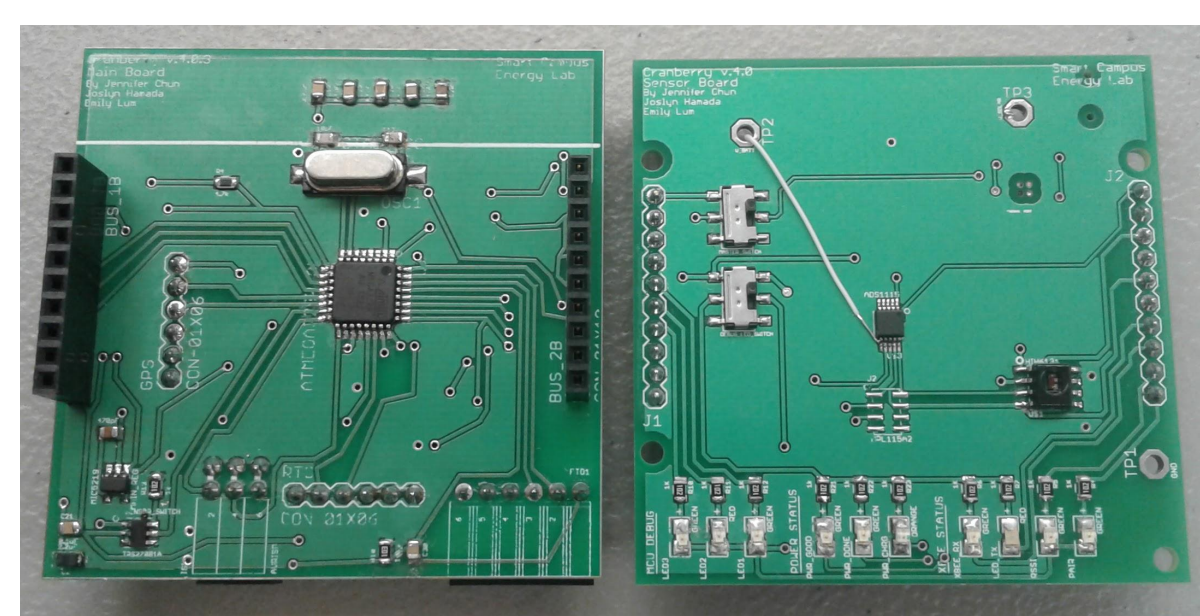

Figure 6: Populated Cranberry 4.0



Figure 7: 3D Housing Design

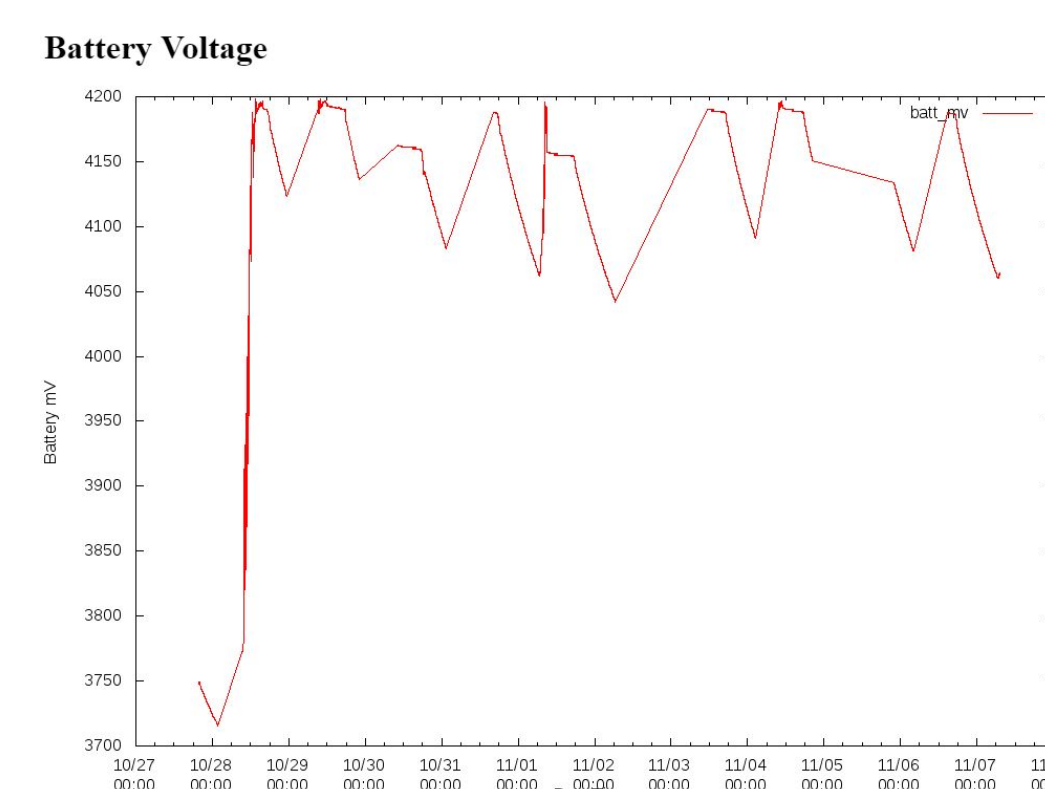

Figure 8: Battery voltage data for the 3rd generation sensor module

Design

Hardware Methods

Power Management

- Incorporate solar panel and rechargeable battery
- Utilize solar charging chip for self-sufficiency

Low Cost

- Design own sensor circuit using Eagle
- Print 3D Housing made by Housing Team

Increased Functionality

- Utilize GPS for future data tracking purposes
- Include Real Time Clock separate from GPS to timestamp data and provide lower power consumption

Communication

- Transmit sensor and diagnostic data using an XBee Pro S2B, which has a maximum range of 1 mile
- Use smaller relay nodes to extend the range of the sensor network

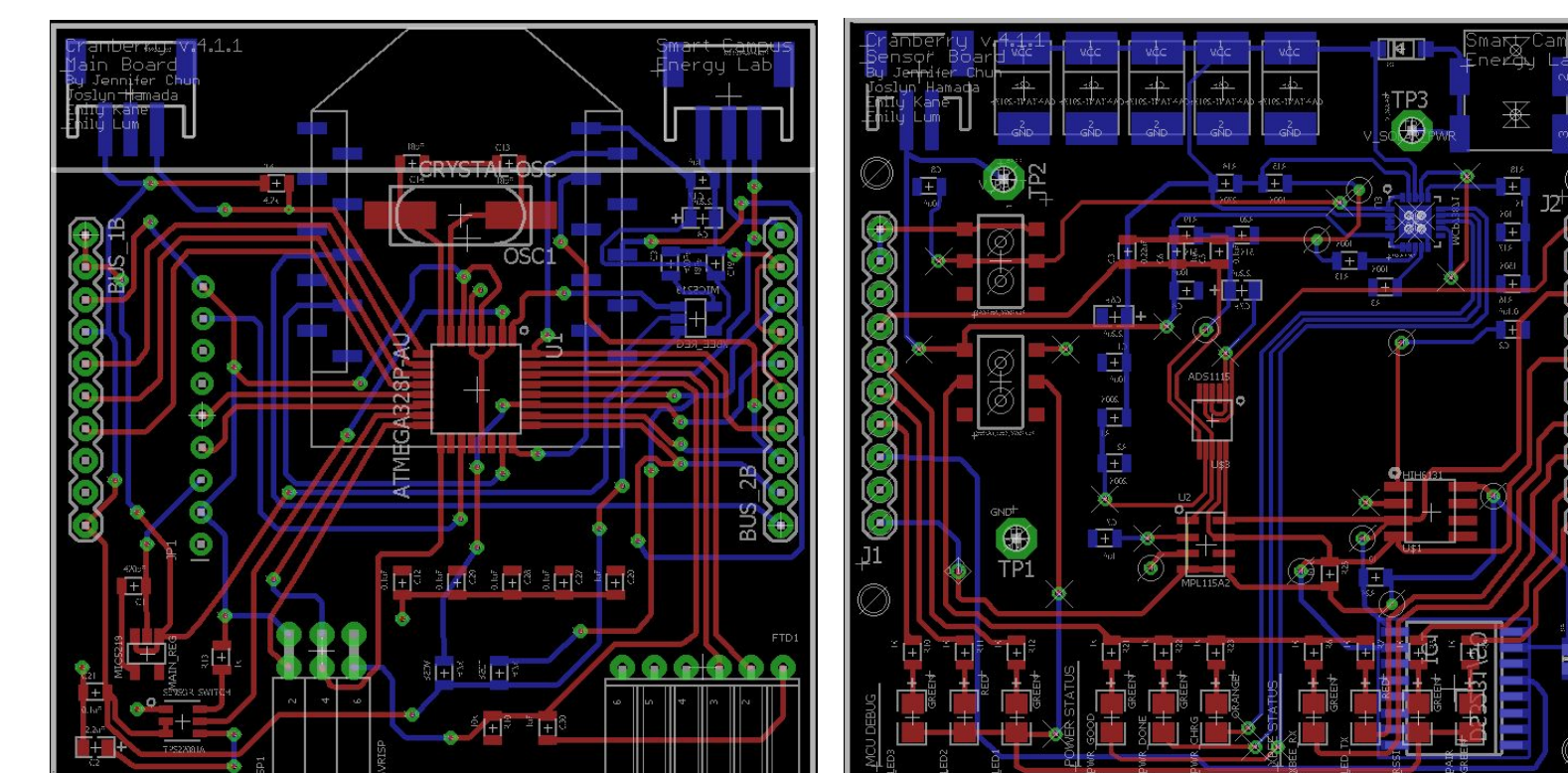

Figure 5: Cranberry v4.1 PCB (2.375" by 2.375")

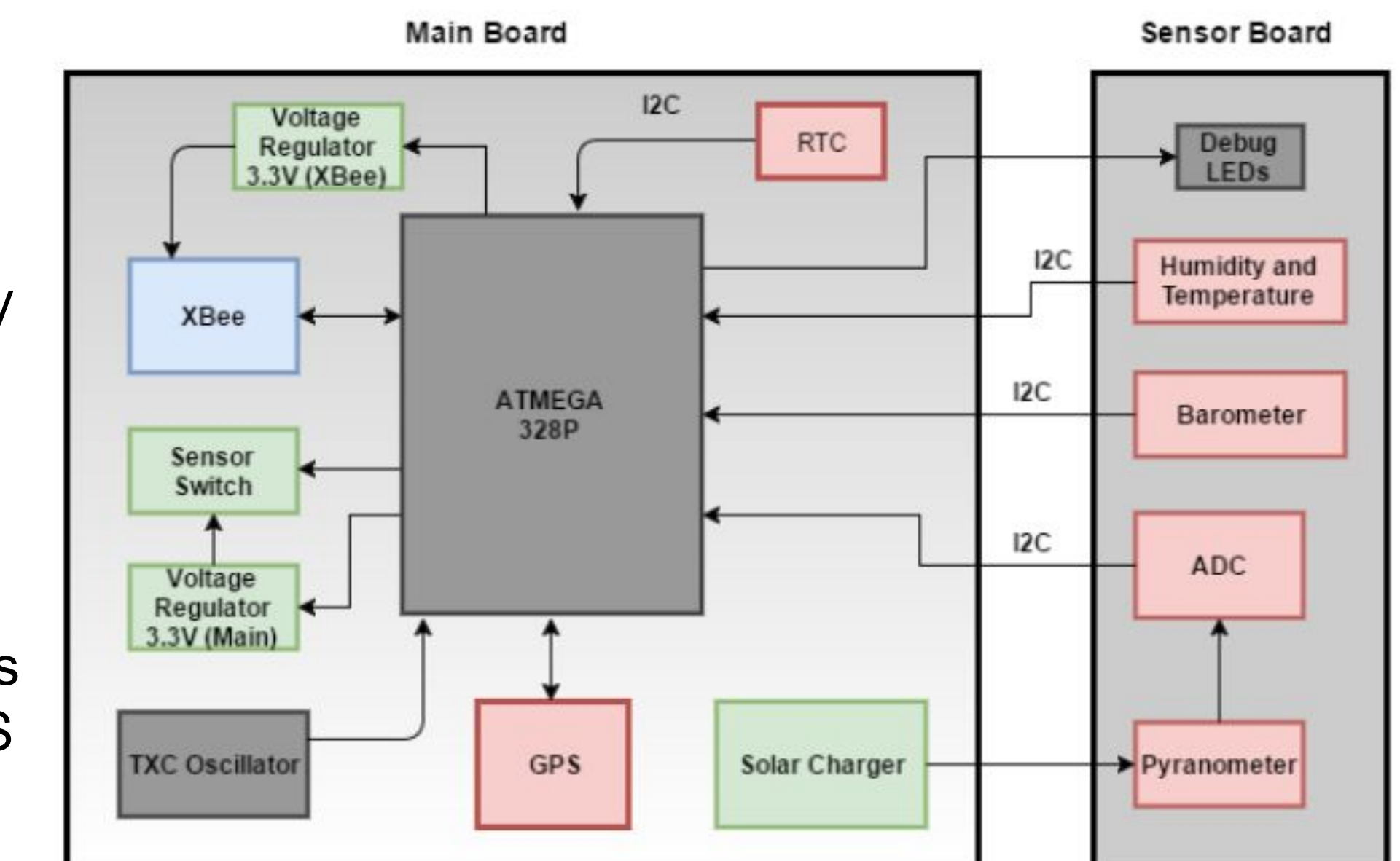

Figure 3: Hardware block diagram

Firmware Methods

Data Encoding

- Heartbeat packet contains diagnostic data
- Data packet contains sensor data

Data Collection

- Gather diagnostic data and sensor data
- Different sampling rates for different data packets

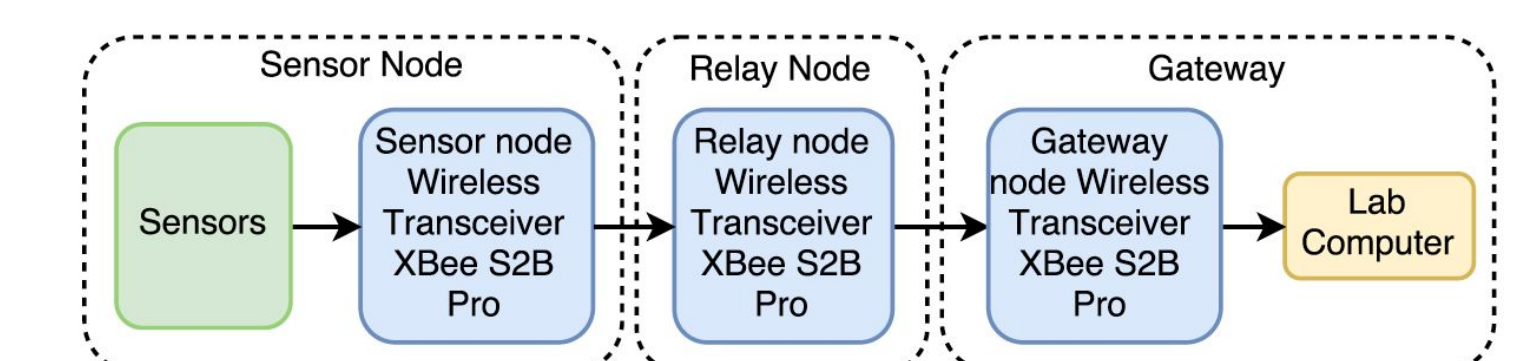

Figure 4: Relay node block diagram

Conclusion

Key Work

- Deployed one Cranberry v4.0 board
- Completed soldering two Cranberry v4.1 boards

Future Work

- Implement firmware for real time clock and GPS
- Design new Cranberry generation with further improvements
 - Shrinking Cranberry back to original 2" by 2"
 - Fixing potential issues found with Cranberry v4.1



Figure 9: Deployed Cranberry v3.5

Acknowledgments

Dr. Anthony Kuh, UHM College of Engineering and the Department of Electrical Engineering
Industry Sponsors: Johnson Controls, National Science Foundation, Raytheon