

Wind Sensor

Preliminary Design Review

Keoni Davey

Binguang Wang

Scott Nishihara

Alex Noveloso

Block Diagram

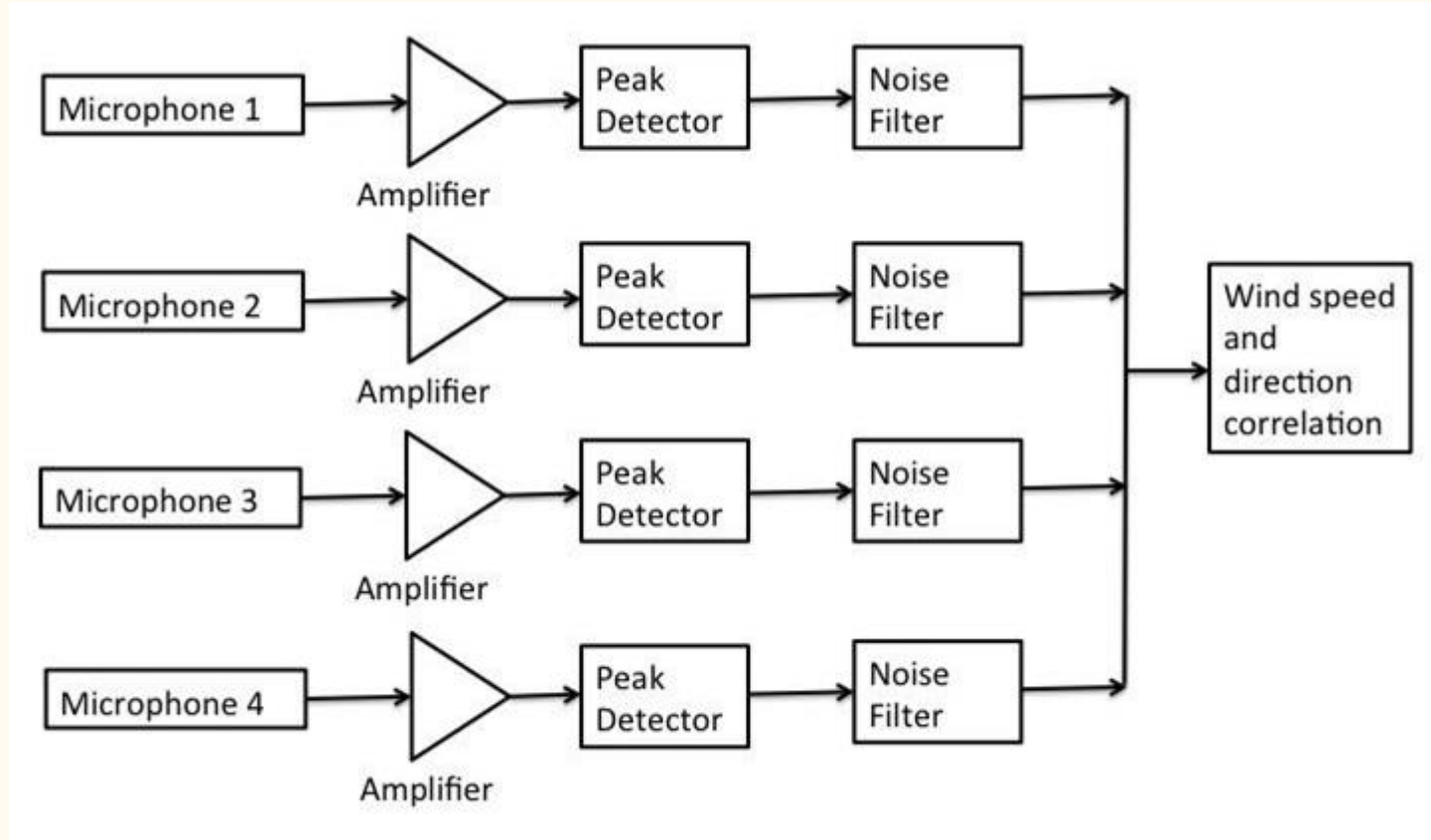

Progress

Recreated wind speed & direction experiments.

Finished Arduino tutorials; beginning Teensy tutorials.

Determined direction for project

- Teensy 3.2 with the Cortex-M4 processor

- Teensy directly to Matlab via UART

Set up mentoring meetings with Andy & Daisy

Re-tested anemometer calibration

Problems and Issues

Calibration

Current Anemometer doesn't send real time data.

Hooking up to computer doesn't work

Previously no clear direction

Mentoring helped (discussed options)

Need Parts & Breadboard

Microphone consistency

Manually adjusting & selecting microphones



Goals

Shift from Teensy to Arduino

Compatible code (Teensyduino)

Test on breadboard

Research Teensy to Matlab via UART

Instead of manually reading serial monitor, transmit directly

Research & Program Cortex-M4 chips

For implementation on PCB

Design PCB

Questions?